

FW
R1.50

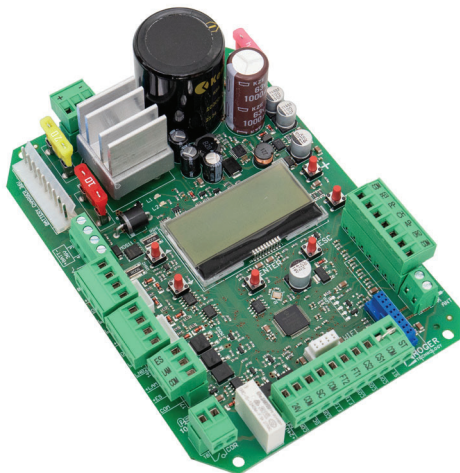

IS247 Rev.00 30/11/2023

F70/IPU36

centrale di comando per motori BRUSHLESS IPU TECHNOLOGY

Istruzioni originali



EN - Instructions and warnings for the installer



ENGLISH

1	Symbols	68
2	Product description	68
3	Updates of version R1.50	68
4	Technical characteristics of product	69
5	Description of connections	70
6	Commands and Accessories	72
7	Function buttons and display	74
8	Light signals	74
9	Navigation in the menus	75
10	Menu	75
11	Index of parameters	100
12	Parameter menu	103
13	Alarms and faults	114
14	Inverter module	114
15	Mechanical release	115
16	Position recovery procedure in the ABSENCE of limit switches	115
17	Initial testing	116
18	Declaration of Conformity	116

Illustrazioni e schemi - Pictures and schemes - Bilder und Pläne Illustrations et schémas - Ilustraciones y esquemas - Ilustrações e esquemas

FW
R1.50

Indicazione versione hardware (HW)
Hardware version indication (HW)

TARGET: IPU R1.50
HW: 2

L1 = Led ROSSO di segnalazione
RED signalling LED
L2 = Led VERDE di segnalazione
GREEN signalling LED
BATT = Segnalazione batteria invertita
Reverse battery warning

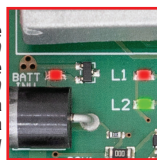

ENTER ESC

Fusibile 10A
Fuse 10A

Fusibile 15A
Fuse 20A

Ingresso alimentazione (secondario trasformatore)
Power supply unit (transformer's secondary)

Fusibile 4A
Fuse 4A

Connettore scheda carica batterie (3 x 12V=== 4.5Ah)
Plug for battery charger (3 x 12V=== 4.5Ah)

Collegamento batterie 36V e resistenza di frenatura (*)
36V battery connection and braking resistor (*)

Collegamento MOTORE 1 (cavo 4 fili)
MOTOR 1 connection (4 wiring cable)

EXP1, connettore accessori RS485
EXP1, RS485 accessory connector

EXP2, connettore accessori RS485
EXP2, RS485 accessory connector

Collegamento MOTORE 2 (cavo 4 fili)
MOTOR 2 connection (4 wiring cable)

Morsettiere lampeggiante ed elettroserratura
Flashing light and electric lock terminal blocks

Luce di cortesia
Courtesy light

Microcontrollore DSP 70 MIPS
DSP CPU 70 MIPS

Morsettiere delle sicurezze
Safeties terminal blocks

Connettore per applicazione WiFi B74/BCONNECT
Connector for B74/BCONNECT WiFi application

Display LCD retroilluminato 128x64 punti e 6 tasti di programmazione
128x64 dots backlit LCD display and 6 programming keys

Morsettiere dei comandi
Commands terminal blocks

Connettore ad innesto per radio ricevente
Plug-in connector for radio receiver

Dispositivo IP B74/BCONNECT
B74/BCONNECT IP device



ATTENZIONE: la centrale F70/IPU36 non è compatibile con le serie BM30, BH30, BG30, MONOS, BE20, BR20, SMARTY, BR21, AYRON, BH23, BIONIK, BR41.

ATTENTION: the F70/IPU36 control unit is not compatible with the BM30, BH30, BG30, MONOS, BE20, BR20, SMARTY, BR21, AYRON, BH23, BIONIK, BR41 series.

F70/IPU36/BOX

1

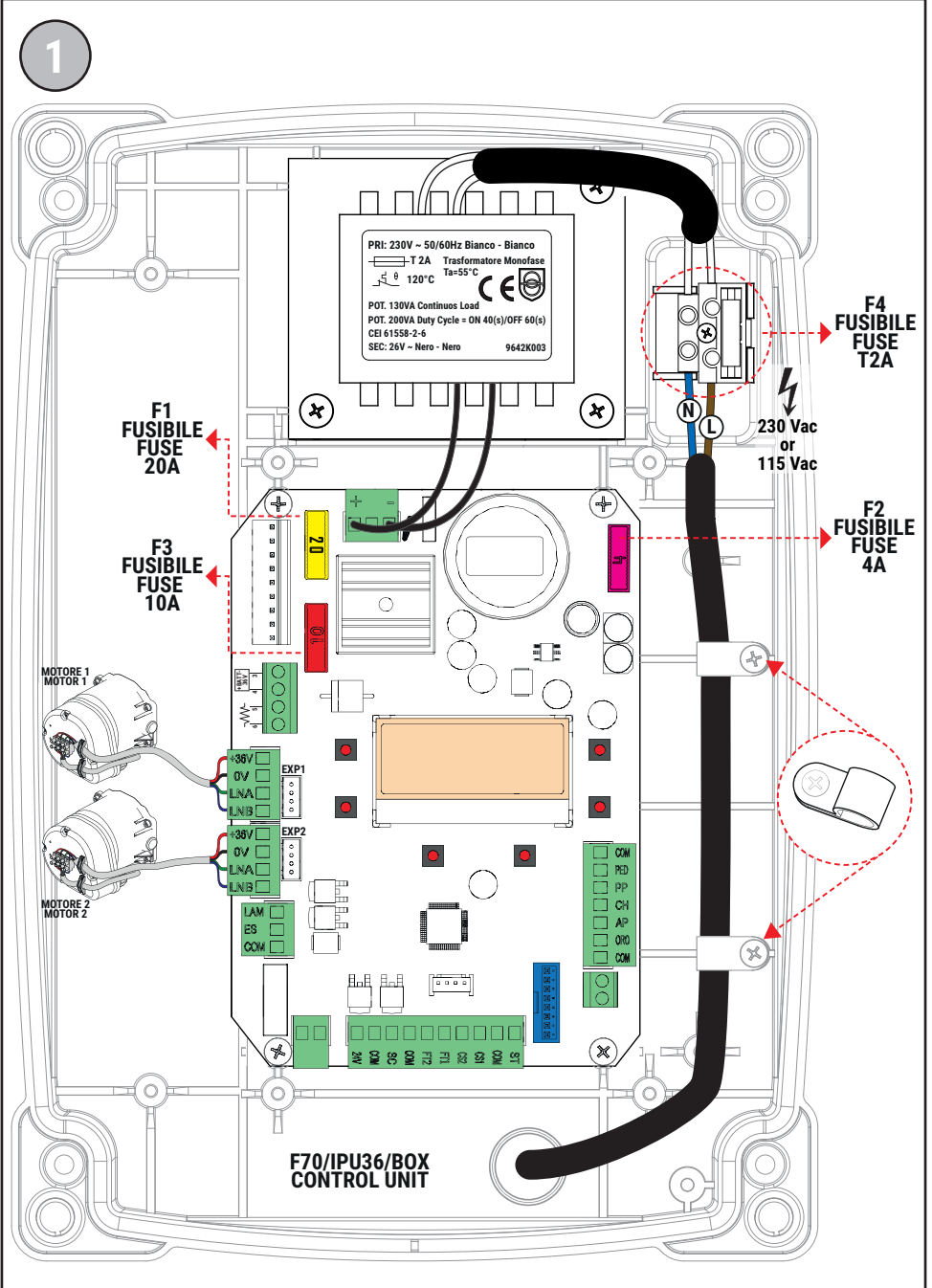

F70/IPU36/BOX/SL

1

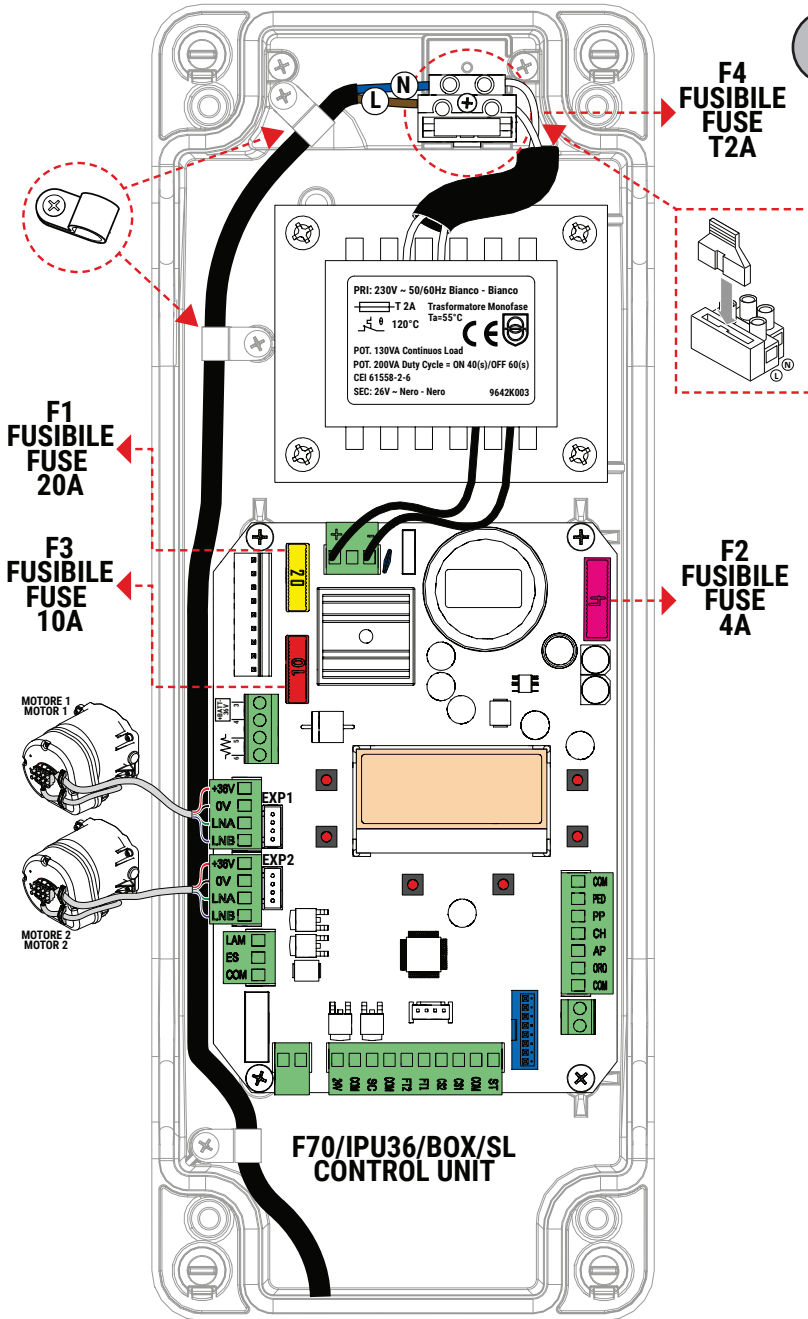

2

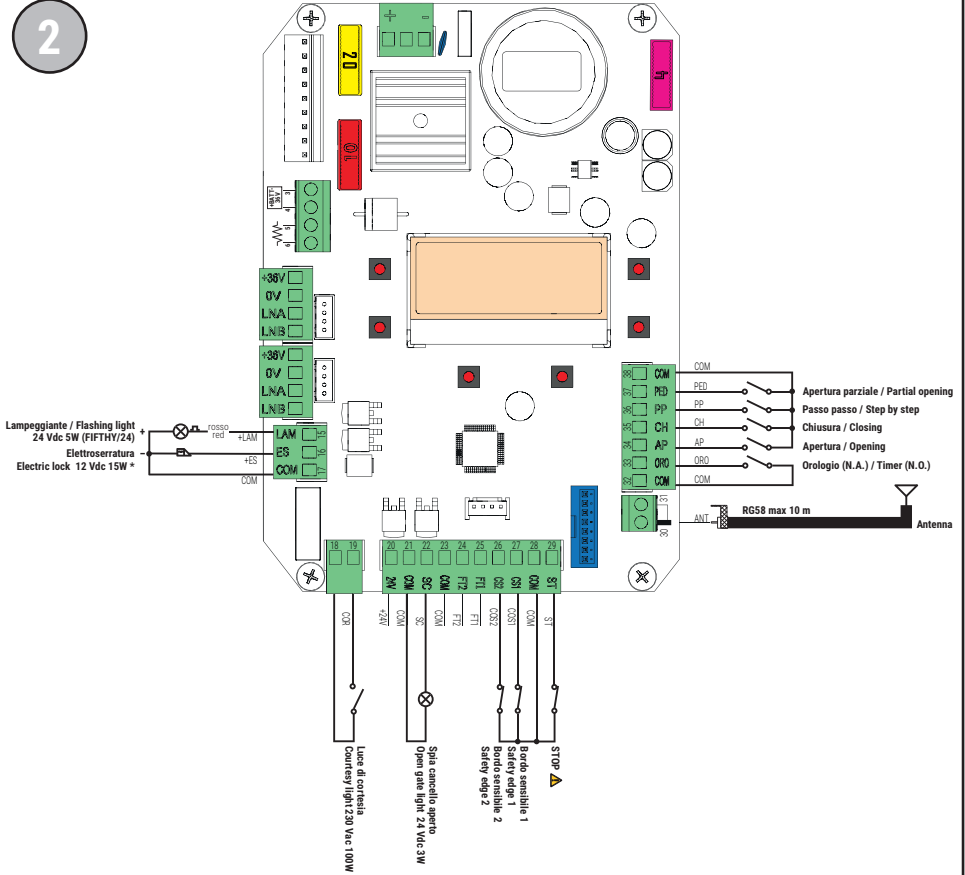

(*) $V_{media}=12V_{---}$; $V_{max}=40V_{---}$
 (*) $V_{average}=12V_{---}$; $V_{max}=40V_{---}$

3

Utilizzo alternativo dell'uscita COR (par. IB diverso da 00).
 Alternative use of COR output (par. IB different from 00).

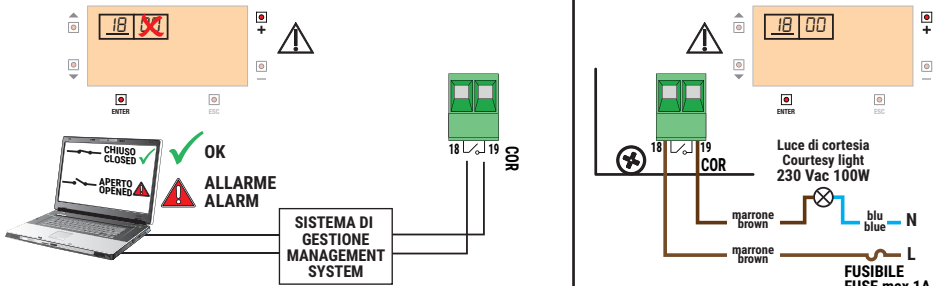

COLLEGAMENTO CON 1 COPPIA FOTOCELLE SINCROZZATE (MODALITÀ NORMALE, SOLO COPPIA MASTER)
CONNECTION WITH 1 SYNCHRONISED PHOTOCCELL PAIR (NORMAL MODE, MASTER PAIR ONLY)

ROSSO = libero da jumper
 RED = jumper free

4

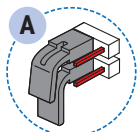
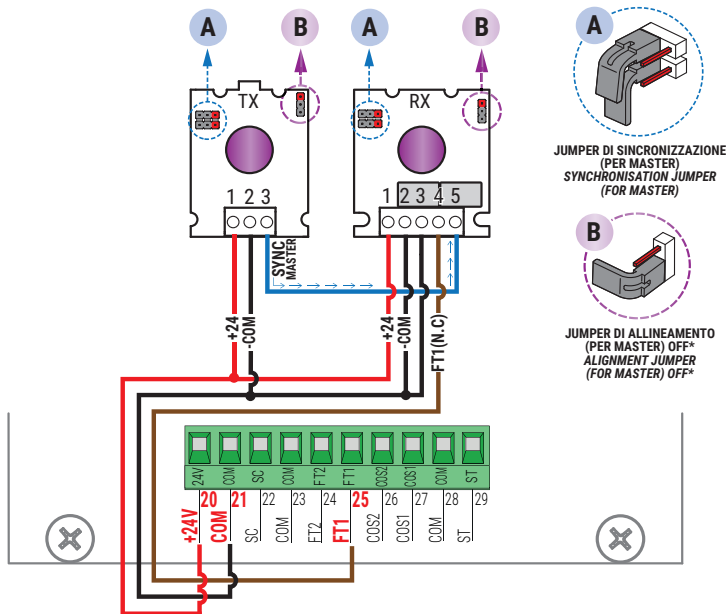

JUMPER DI SINCROZZAZIONE (PER MASTER)
SYNCHRONISATION JUMPER (FOR MASTER)

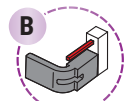

JUMPER DI ALLINEAMENTO (PER MASTER OFF*)
ALIGNMENT JUMPER (FOR MASTER OFF*)

* Per eseguire la modalità in di allineamento ottico (NOTA: consultare le istruzioni delle fotocelle):
 * To perform optical alignment mode (NOTE: refer to photocell instructions):

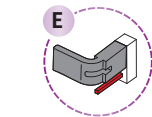
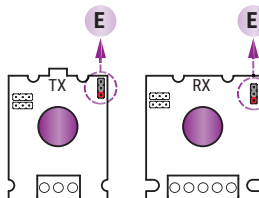

JUMPER DI ALLINEAMENTO ON*
ALIGNMENT JUMPER ON*



ATTENZIONE! Modificare la posizione dei jumper di sincronizzazione o di allineamento solamente quando le fotocelle sono **NON ALIMENTATE!** La configurazione scelta con i jumper viene memorizzata dalle fotocelle solamente all'accensione delle fotocelle.

Scollegare la morsetteria della centrale che fornisce alimentazione alle fotocelle, oppure togliere completamente la tensione al controller digitale (scollegando, se presenti, anche le batterie di backup) e verificare nella fotocella TX / RX che il LED rosso di alimentazione sia spento; procedere soltanto ora all'impostazione della configurazione dei jumper.

ATTENTION! Please ensure that the photocell jumpers are only changed with the power to the control panel switched off, including the disconnection of any battery backup. Remove the terminal of the photocell inputs or completely remove the voltage from the digital controller (check that the digital controller is not powered by backup batteries) and check that the TX / RX photocell red power LED is off.

SI RACCOMANDA L' USO DI fotocelle Serie **F4ES - F4S** / **RECOMMENDED USE for** Series **F4ES - F4S** photocells

COLLEGAMENTO CON 2 COPPIE FOTOCELLE SINCRONIZZATE (MODALITÀ NORMALE, 1 MASTER E 1 SLAVE)
CONNECTION WITH 2 SYNCHRONISED PHOTOCELL PAIRS (NORMAL MODE, 1 MASTER AND 1 SLAVE)

ROSSO = libero da jumper
 RED = jumper free

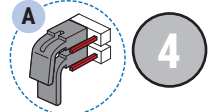
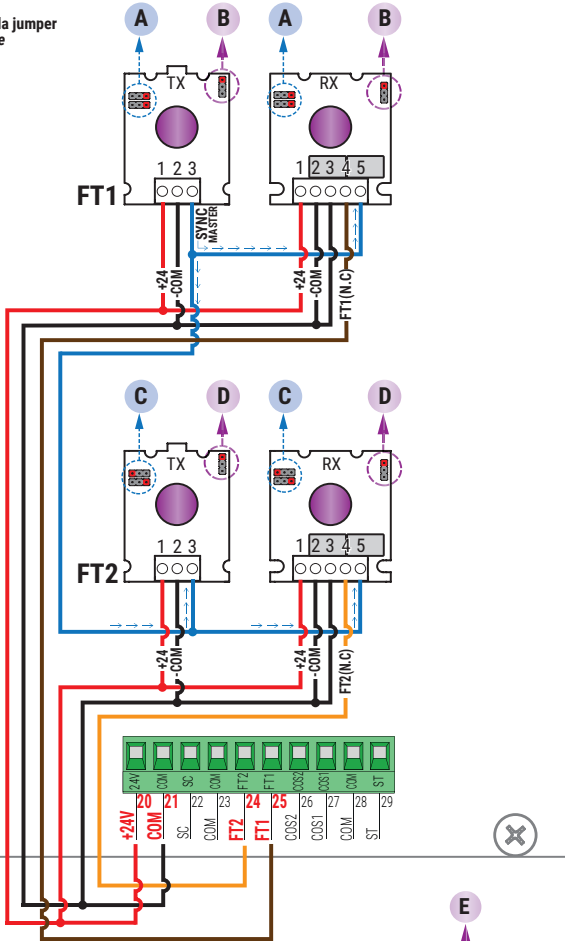

JUMPER DI SINCRONIZZAZIONE (PER MASTER)
SYNCHRONISATION JUMPER (FOR MASTER)

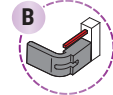

JUMPER DI ALLINEAMENTO (PER MASTER) OFF*
ALIGNMENT JUMPER (FOR MASTER) OFF*

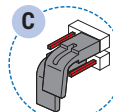

JUMPER DI SINCRONIZZAZIONE (PER SLAVE)
SYNCHRONISATION JUMPER (FOR SLAVE)

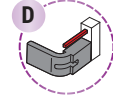

JUMPER DI ALLINEAMENTO (PER SLAVE) OFF*
ALIGNMENT JUMPER (FOR SLAVE) OFF*

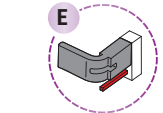
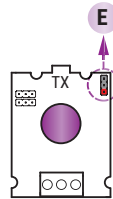

JUMPER DI ALLINEAMENTO ON*
ALIGNMENT JUMPER ON*

* Per eseguire la modalità in di allineamento ottico
 (NOTA: consultare le istruzioni delle fotocelle):
 * To perform optical alignment mode
 (NOTE: refer to photocell instructions):



ATTENZIONE! Modificare la posizione dei jumper di sincronizzazione o di allineamento solamente quando le fotocelle sono **NON ALIMENTATE!** La configurazione scelta con i jumper viene memorizzata dalle fotocelle solamente all'accensione delle fotocelle.

Scollegare la morsetteria della centrale che fornisce alimentazione alle fotocelle, oppure togliere completamente la tensione al controller digitale (scollegando, se presenti, anche le batterie di backup) e verificare nella fotocella TX / RX che il LED rosso di alimentazione sia spento; procedere soltanto ora all'impostazione della configurazione dei jumper.

ATTENTION! Please ensure that the photocell jumpers are only changed with the power to the control panel switched off, including the disconnection of any battery backup. Remove the terminal of the photocell inputs or completely remove the voltage from the digital controller (check that the digital controller is not powered by backup batteries) and check that the TX / RX photocell red power LED is off.

SI RACCOMANDA L'USO DI fotocelle Serie F4ES - F4S / RECOMMENDED USE for Series F4ES - F4S photocells

TEST FOTOCELLE · PHOTOCELLS TEST (AB 02)

COLLEGAMENTO CON 1 COPPIA FOTOCELLE SINCRONIZZATE (MODALITÀ NORMALE, SOLO COPPIA MASTER) CONNECTION WITH 1 SYNCHRONISED PHOTOCCELL PAIR (NORMAL MODE, MASTER PAIR ONLY)

ROSSO = libero da jumper
RED = jumper free

5

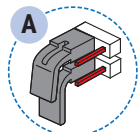
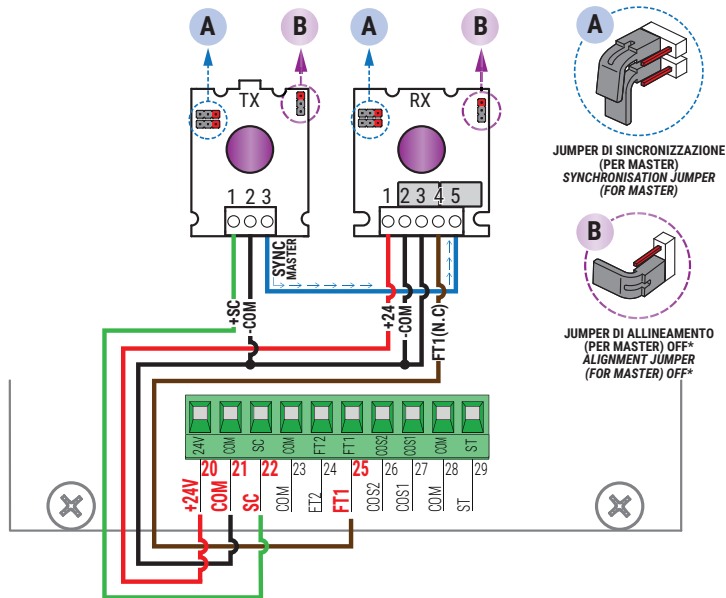

JUMPER DI SINCRONIZZAZIONE
(PER MASTER)
SYNCHRONISER JUMPER
(FOR MASTER)

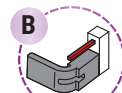

JUMPER DI ALLINEAMENTO
(PER MASTER OFF)
ALIGNMENT JUMPER
(FOR MASTER OFF)*

* Per eseguire la modalità in di allineamento ottico
(NOTA: consultare le istruzioni delle fotocelle):
* To perform optical alignment mode
(NOTE: refer to photocell instructions):

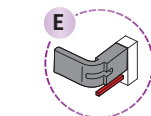
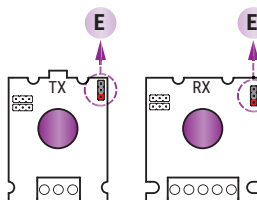

JUMPER DI ALLINEAMENTO ON*
ALIGNMENT JUMPER ON*



ATTENZIONE! Modificare la posizione dei jumper di sincronizzazione o di allineamento solamente quando le fotocelle sono **NON ALIMENTATE!** La configurazione scelta con i jumper viene memorizzata dalle fotocelle solamente all'accensione delle fotocelle.

Scollegare la morsetteria della centrale che fornisce alimentazione alle fotocelle, oppure togliere completamente la tensione al controller digitale (scollegando, se presenti, anche le batterie di backup) e verificare nella fotocella TX / RX che il LED rosso di alimentazione sia spento; procedere soltanto ora all'impostazione della configurazione dei jumper.

ATTENTION! Please ensure that the photocell jumpers are only changed with the power to the control panel switched off, including the disconnection of any battery backup. Remove the terminal of the photocell inputs or completely remove the voltage from the digital controller (check that the digital controller is not powered by backup batteries) and check that the TX / RX photocell red power LED is off.

SI RACCOMANDA L'USO DI fotocelle Serie F4ES - F4S / RECOMMENDED USE for Series F4ES - F4S photocells

TEST FOTOCELLE · PHOTOCELLS TEST (AB 02)

COLLEGAMENTO CON 2 COPPIE FOTOCELLE SINCRONIZZATE (MODALITÀ NORMALE, 1 MASTER E 1 SLAVE) CONNECTION WITH 2 SYNCHRONISED PHOTOCCELL PAIRS (NORMAL MODE, 1 MASTER AND 1 SLAVE)

ROSSO = libero da jumper
RED = jumper free

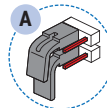
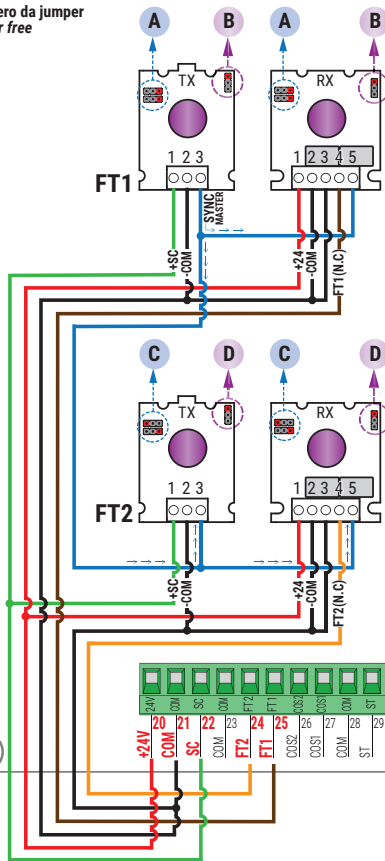

JUMPER DI SINCRONIZZAZIONE (PER MASTER)
SYNCHRONISATION JUMPER (FOR MASTER)

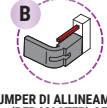

JUMPER DI ALLINEAMENTO (PER MASTER) OFF*
ALIGNMENT JUMPER (FOR MASTER) OFF*

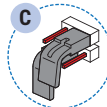

JUMPER DI SINCRONIZZAZIONE (PER SLAVE1)
SYNCHRONISATION JUMPER (FOR SLAVE1)

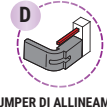

JUMPER DI ALLINEAMENTO (PER SLAVE1) OFF*
ALIGNMENT JUMPER (FOR SLAVE1) OFF*

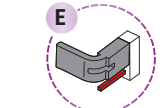
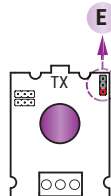

JUMPER DI ALLINEAMENTO ON*
ALIGNMENT JUMPER ON*

* Per eseguire la modalità in di allineamento ottico
(NOTA: consultare le istruzioni delle fotocelle):
* To perform optical alignment mode
(NOTE: refer to photocell instructions):



ATTENZIONE! Modificare la posizione dei jumper di sincronizzazione o di allineamento solamente quando le fotocelle sono **NON ALIMENTATE!** La configurazione scelta con i jumper viene memorizzata dalle fotocelle solamente all'accensione delle fotocelle.

Scollegare la morsetteria della centrale che fornisce alimentazione alle fotocelle, oppure togliere completamente la tensione al controller digitale (scollegando, se presenti, anche le batterie di backup) e verificare nella fotocella TX / RX che il LED rosso di alimentazione sia spento; procedere soltanto ora all'impostazione della configurazione dei jumper.

ATTENTION! Please ensure that the photocell jumpers are only changed with the power to the control panel switched off, including the disconnection of any battery backup. Remove the terminal of the photocell inputs or completely remove the voltage from the digital controller (check that the digital controller is not powered by backup batteries) and check that the TX / RX photocell red power LED is off.

SI RACCOMANDA L'USO DI fotocelle Serie F4ES - F4S / RECOMMENDED USE for Series F4ES - F4S photocells

BATTERY SAVING (AB 03)

BATTERY SAVING + TEST FOTOCELLULE · PHOTOCELLS TEST (AB 04)

COLLEGAMENTO CON 1 COPPIA FOTOCELLULE SINCRONIZZATE (MODALITÀ NORMALE, SOLO COPPIA MASTER) CONNECTION WITH 1 SYNCHRONISED PHOTOCCELL PAIR (NORMAL MODE, MASTER PAIR ONLY)

ROSSO = libero da jumper
RED = jumper free

6

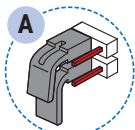
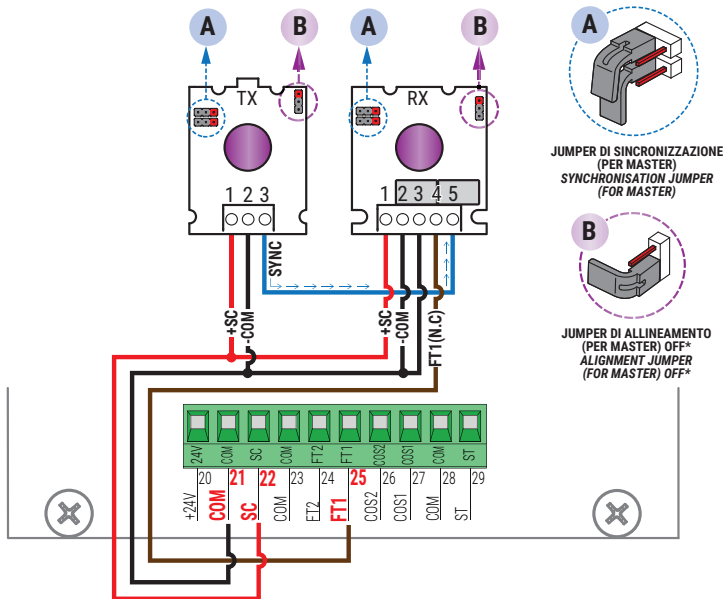

JUMPER DI SINCRONIZZAZIONE (PER MASTER)
SYNCHRONISATION JUMPER (FOR MASTER)

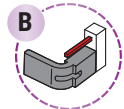

JUMPER DI ALLINEAMENTO (PER MASTER OFF)
ALIGNMENT JUMPER (FOR MASTER OFF*)

* Per eseguire la modalità in di allineamento ottico
(NOTA: consultare le istruzioni delle fotocellule):
* To perform optical alignment mode
(NOTE: refer to photocell instructions):

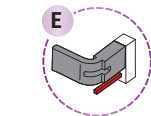
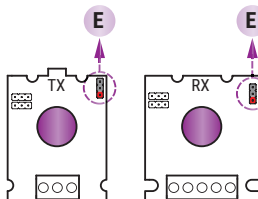

JUMPER DI ALLINEAMENTO ON*
ALIGNMENT JUMPER ON*



ATTENZIONE! Modificare la posizione dei jumper di sincronizzazione o di allineamento solamente quando le fotocellule sono **NON ALIMENTATE!** La configurazione scelta con i jumper viene memorizzata dalle fotocellule solamente all'accensione delle fotocellule.

Scollegare la morsetteria della centrale che fornisce alimentazione alle fotocellule, oppure togliere completamente la tensione al controller digitale (scollegando, se presenti, anche le batterie di backup) e verificare nella fotocellula TX / RX che il LED rosso di alimentazione sia spento; procedere soltanto ora all'impostazione della configurazione dei jumper.

ATTENTION! Please ensure that the photocell jumpers are only changed with the power to the control panel switched off, including the disconnection of any battery backup. Remove the terminal of the photocell inputs or completely remove the voltage from the digital controller (check that the digital controller is not powered by backup batteries) and check that the TX / RX photocell red power LED is off.

SI RACCOMANDA L' USO DI fotocellule Serie **F4ES - F4S** / **RECOMMENDED USE for** Series **F4ES - F4S** photocells

BATTERY SAVING (AB 03)

BATTERY SAVING + TEST FOTOCELLULE · PHOTOCELLS TEST (AB 04)

COLLEGAMENTO CON 2 COPPIE FOTOCELLULE SINCRONIZZATE (MODALITÀ NORMALE, 1 MASTER E 1 SLAVE) CONNECTION WITH 2 SYNCHRONISED PHOTOCCELL PAIRS (NORMAL MODE, 1 MASTER AND 1 SLAVE)

ROSSO = libero da jumper
RED = jumper free

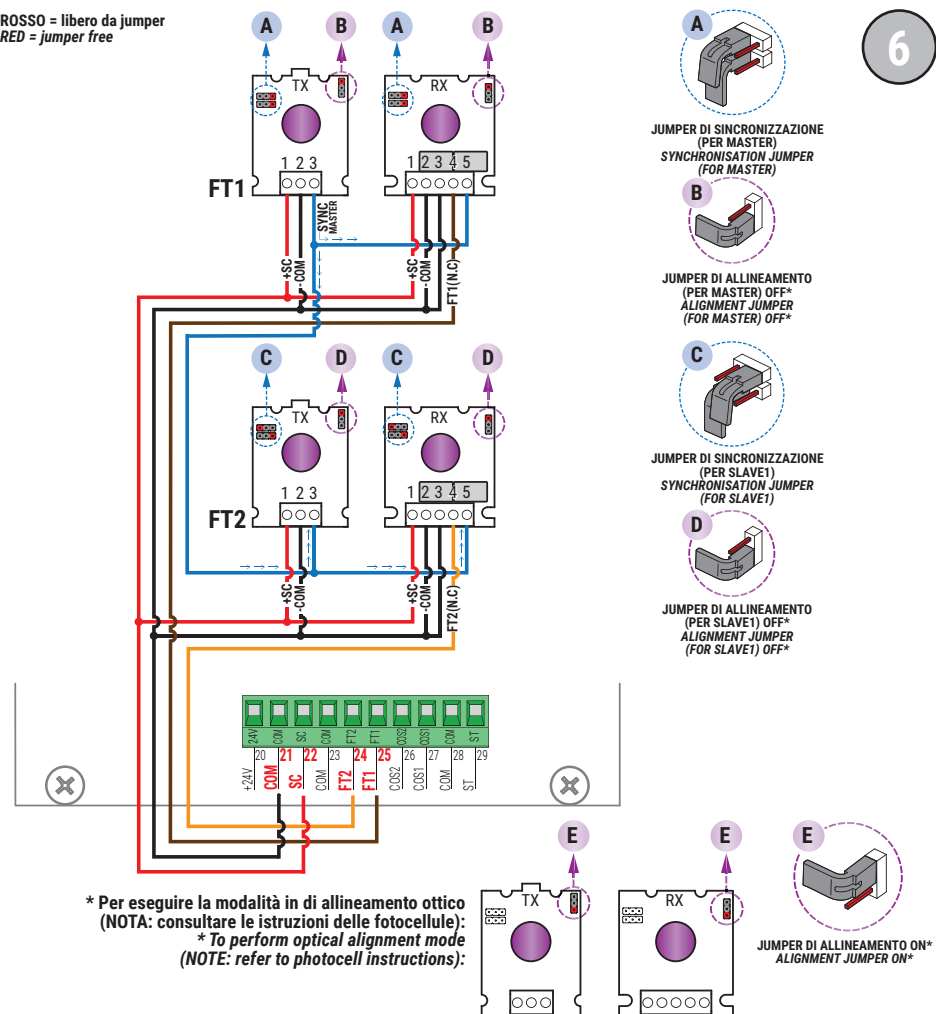

* Per eseguire la modalità in di allineamento ottico
(NOTA: consultare le istruzioni delle fotocellule):
* To perform optical alignment mode
(NOTE: refer to photocell instructions):



ATTENZIONE! Modificare la posizione dei jumper di sincronizzazione o di allineamento solamente quando le fotocellule sono **NON ALIMENTATE!** La configurazione scelta con i jumper viene memorizzata dalle fotocellule solamente all'accensione delle fotocellule.

Scollegare la morsetteria della centrale che fornisce alimentazione alle fotocellule, oppure togliere completamente la tensione al controller digitale (scollegando, se presenti, anche le batterie di backup) e verificare nella fotocellula TX / RX che il LED rosso di alimentazione sia spento; procedere soltanto ora all'impostazione della configurazione dei jumper.

ATTENTION! Please ensure that the photocell jumpers are only changed with the power to the control panel switched off, including the disconnection of any battery backup. Remove the terminal of the photocell inputs or completely remove the voltage from the digital controller (check that the digital controller is not powered by backup batteries) and check that the TX / RX photocell red power LED is off.

SI RACCOMANDA L'USO DI fotocellule Serie **F4ES - F4S** / **RECOMMENDED USE for** Series **F4ES - F4S** photocells

**B71/BCIPU
CARICA BATTERIE
BATTERY CHARGER**

PRIMARIO: 230V - 50/60Hz BIANCO
 ← T 2A Trasformatore Monofase
 T_{amb} 120°C
 CEI 61558-2-6
 POT. 130VA
 T_{amb} 55°C
 SECONDARIO: 26V NERO

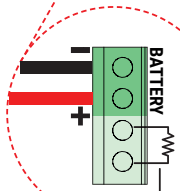

Se richiesto dall'automazione, collegare una resistenza di adeguata potenza per assorbire l'energia in frenata.
 If required by the automation, connect a resistor of adequate power to absorb the braking energy.

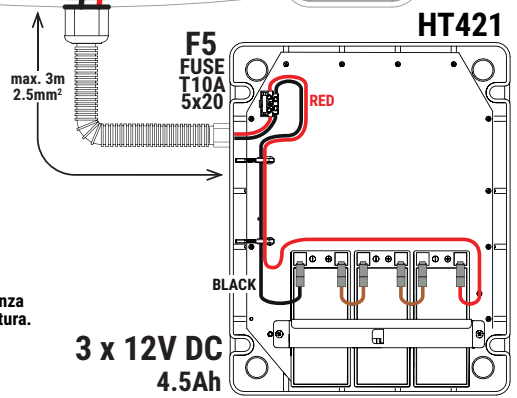

! AGM Battery ONLY

ELETTRONICA DI COMANDO A BORDO MOTORE (F70/INV36/1) ON-BOARD MOTOR COMMAND ELECTRONIC UNIT (F70/INV36/1)

8

TARGET: **MOT** R1.20
HW:1 IFW:
SERN:
R485: BOOT:1.30

NOTA: la versione del FW dell'inverter (es. R1.20) non va di pari passo con la versione FW di F70/IPU36
NOTE: the FW version of the inverter (e.g. R1.20) does not match the FW version of the F70/IPU36

ENTER

ESC

Collegamento a elettroblock (opzionale)
Connection to electroblock (optional)

BDDW = contatto "elettroblock inserito" (N.C.)
BDDW = "electroblock on" contact (N.C.)

BDUP = contatto di sblocco (N.C.) o contatto "elettroblock disinserito"
BDUP = unlock contact (N.C.) or "electroblock off" contact (N.C.)

FC2 = finecorsa chiusura (N.C.)
FC2 = closing limit switch (N.C.)

FC1 = finecorsa apertura (N.C.)
FC1 = opening limit switch (N.C.)

Connettore per espansione RS485
RS485 expansion connector

Foro di centraggio
Centring hole

Morsettiera di connessione a F70/IPU36
Terminal block for connection to F70/IPU36

L1M = Led ROSSO di segnalazione
RED signalling LED

L2M = Led VERDE di segnalazione
GREEN signalling LED

Morsettiera di connessione alle fasi motore
Connection terminal block to motor phases

Foro di centraggio
Centring hole

Riferimento MOTORE NV/200/DX - NV/200/SX
MOTOR reference NV/200/DX - NV/200/SX

Morsettiera di connessione a F70/IPU36
Terminal block for connection to F70/IPU36

Morsettiera di connessione all'elettronica di comando a bordo motore

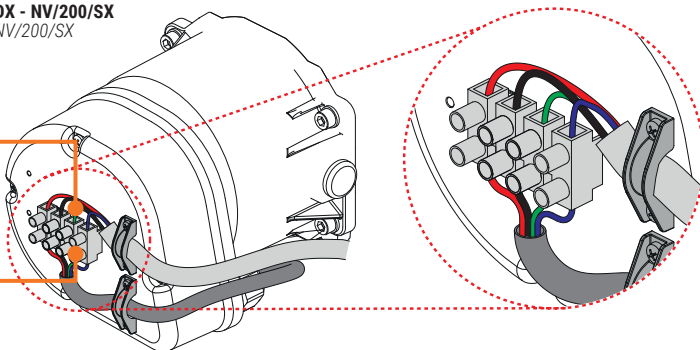

Il collegamento della centrale al motore deve essere eseguito in assenza di alimentazione di rete/batteria
The connection of the control unit to the motor must be carried out without mains/battery supply

MODALITÀ FUNZIONAMENTO B73/RGB B73/RGB OPERATING MODE

9

LED ROSSO FISSO
FIXED RED LED

LED ROSSO LAMPEGGIANTE
(lampeggio continuo)
RED LED FLASHING
(continuous flashing)

LED ROSSO DI PRESENZA
(lampeggio discontinuo)
RED PRESENCE LED
(discontinuous flashing)

LED VERDE FISSO
FIXED GREEN LED

LED VERDE LAMPEGGIANTE
(lampeggio continuo)
GREEN LED FLASHING
(continuous flashing)

LED VERDE DI PRESENZA
(lampeggio discontinuo)
GREEN PRESENCE LED
(discontinuous flashing)

TIPO / TYPE "A"

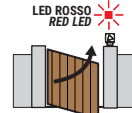
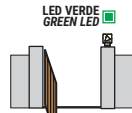
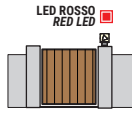

TIPO / TYPE "B"

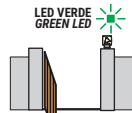
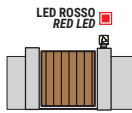

TIPO / TYPE "C"

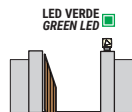

TIPO / TYPE "D"

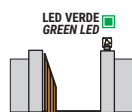
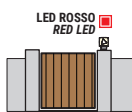

TIPO / TYPE "E"

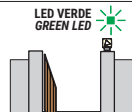
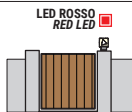

TIPO / TYPE "F"

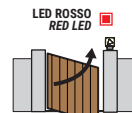
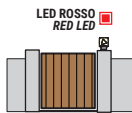

DISPONIBILI SOLO PER PARAMETRO / ONLY AVAILABLE FOR PARAMETER X3=07, X3=08

TIPO / TYPE "G"

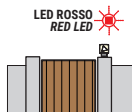

TIPO / TYPE "H"

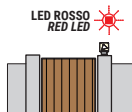



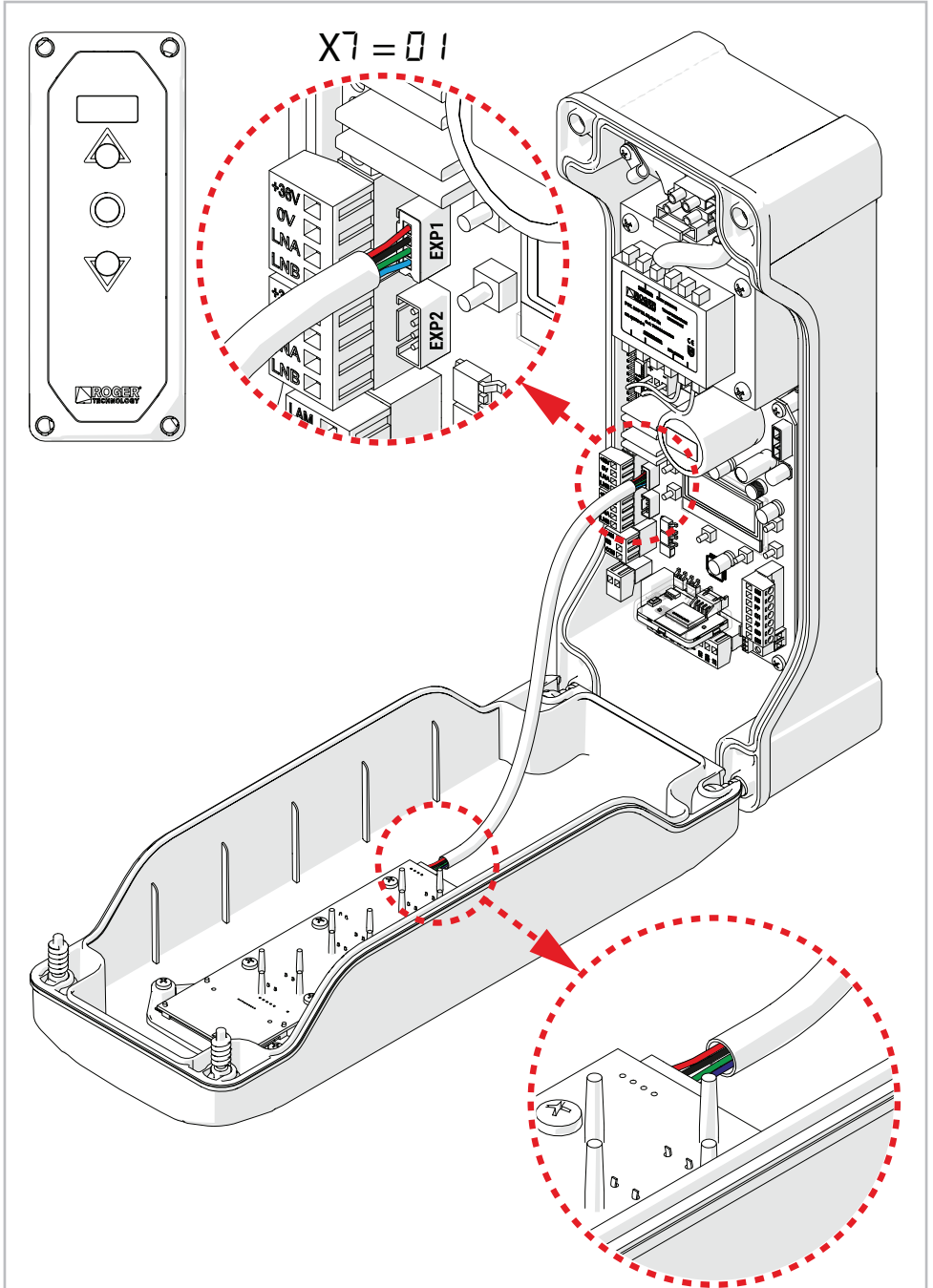





F70/IPU36/BOX/P



1 Symbols

The symbols and their meaning in the manual or on the product label are indicated below.

	Generic danger Important safety information. Indicates operations and situations in which the personnel involved must pay close attention.
	Dangerous voltage risk Indicates operations and situations in which the personnel involved must pay close attention to dangerous voltages.
	Useful information Indicates useful information for the installation.
	Refer to the Installation and use instructions Indicates the obligation to refer to the manual or original document, which must be available for future use and must not be damaged in any way.
	Protective earth connection point.
	Indicates the admissible temperature range.
	Alternating current (AC)
	Direct current (DC)
	Symbol for the product disposal according to the WEEE directive

2 Product description

The **F70/IPU36** control unit is designed to provide logic control of the electronic actuators (inverters) mounted on the motor, so as to realise any one or two motor automation system simply by setting up the parameters in the menu via the backlit LCD interface and the respective selector buttons.

F70/IPU36 transforms the power supplied by the transformer into the required working voltages: 36 V $\overline{\text{---}}$ for the inverter modules and 24 V $\overline{\text{---}}$ for the accessories (flashing light, photocells).

The unit is connected to the motors using 4 conductor cables: two conductors are used for the power supply, while the other two are used for the RS485 serial communication using the ModBus high speed protocol, which provides real-time control over the various machine operating parameters and makes it possible to synchronise the actions of the two motors, in relation to the logic functions requested by the menu parameter settings.

 **Ensure that the parameter $A0$ and $A1$ is set correctly. If this parameter is not set correctly, the automation system may not function properly.**

It is possible to use two different types of automation system on the same gate.

Adjust the opening and closure speed, deceleration and delay settings appropriately for the specific installation, ensuring that the gate leaves overlap correctly.

ROGER TECHNOLOGY cannot be held responsible for any damage or injury due to improper use or any use other than the intended usage indicated in this manual.



We recommend using only ROGER TECHNOLOGY accessories and control and safety devices. Specifically, we recommend installing **F4ES** or **F4S** series photocells.

 **For further information, refer to the automation installation manual.**

3 Updates of version R1.50

- added management of the B73/KEYS control keyboard (parameter X7)
- improved the firmware update menu with management of accessories connected on EXP1 or EXP2 connectors
- added installation date registration menu
- B74/BCONNECT is used to switch the date/time/day of the week to B73/KEYS, in order to enable the TIMER/LOOK functionality of the control keyboard
- added TEST mode
- added man present mode only in closing (par.A7 02)

4 Technical characteristics of product

	F70/IPU36
MAINS POWER VOLTAGE	230 V~ ± 10% 50 Hz (F70/IPU36/115 - 115 V~ ± 10% 60 Hz)
MAXIMUM MAINS POWER ABSORPTION (FROM NETWORK)	230 W
STARTING POWER (FROM NETWORK)	600 W
FUSES	F1 = 20A motor power supply circuit protection F2 = 4A electric lock power supply protection F3 = 10A battery powered circuit protection F4 = T2A transformer primary protection
COMPATIBLE INVERTER MODULES	2
INVERTER MODULES POWER SUPPLY	36V---
INVERTER MODULES SERIAL CONNECTION	RS485, ModBus Protocol, 115200 baud
INVERTER CONTROL TYPE	sensored, with high resolution encoder (on-board motor)
MOTOR TYPE	ROGER BRUSHLESS WITH INVERTER ON BOARD (RS485) - with on-board 36V~ variable frequency inverter - field oriented control (FOC), sensed (high resolution encoder)
RATED POWER PER MOTOR	90 W
STARTING POWER PER MOTOR	250 W
MAXIMUM POWER, FLASHING LIGHT	10 W (24 V---)
FLASHING LIGHT DUTY CYCLE	50%
MAXIMUM POWER	100 W 230 V~ - 40 W 24 V~ / --- (pure contact)
GATE OPEN LIGHT POWER	3 W 24 V---
ELECTRIC LOCK POWER	15 W 12 V--- (mean voltage) (*)
MAXIMUM ACCESSORY CURRENT ABSORPTION	20 W 24 V--- (750 mA - electronic overload protection)
OPERATING TEMPERATURE	 -20°C  +55°C
DEGREE OF PROTECTION	IP54
PRODUCT DIMENSION	F70/IPU36/BOX dimensions in mm 330x230x115 Weight: 3,9 kg F70/IPU36/BOX/SL dimensions in mm 380X145x130 Weight: 4,5 kg F70/IPU36/BOX/P dimensions in mm 380X145x130 Weight: 4,6 kg

(*) The electric lock output provides a voltage of 36V--- nominal (max 40V---) modulated to 30% (30% ON, 70% OFF). The device to be connected must therefore be able to withstand a maximum voltage of 40V---.



The total of the absorption values of all the accessories connected must not exceed the maximum power values shown in the table. The values are guaranteed with original ROGER TECHNOLOGY accessories ONLY. The use of non-original accessories may lead to malfunctioning. ROGER TECHNOLOGY declines all responsibility for incorrect or non-conforming installations. All the connections are protected by fuses (refer to the table). The courtesy light requires an external fuse.

All the connections are protected by fuses (refer to the table). The courtesy light requires an external fuse.

5 Description of connections

5.1 Typical installation

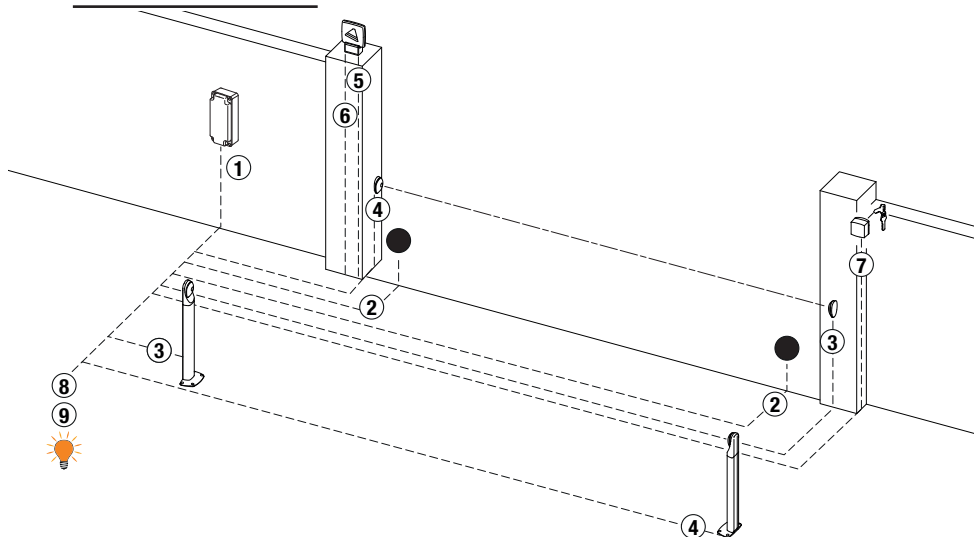

It is the installer's responsibility to verify the adequacy of the cables in relation to the devices used in the installation and their technical characteristics.

		Recommended cable
1	Power supply	H07RN-F 2x1,5 mm ² double insulated cable
2	Motor 1, Motor 2	Cable 4x1,5 mm ² (max 10 m) - 4x2,5 mm ² (max 20 m) - 4x4 mm ² (max 30 m) *
3	Photocells - Receiver F4ES/F4S	Cable 5x0,5 mm ² (max 20 m)
4	Photocells - Transmitter F4ES/F4S	Cable 3x0,5 mm ² (max 20 m)
5	LED Flashing light R92/LED24 - FIFTHY/24 LED 24V ⁻⁻⁻ power supply	Cable 2x1 mm ² (max 10 m)
6	Antenna	Cable 50 Ohm RG58 (max 10 m)
	Key selector R85/60	Cable 3x0,5 mm ² (max 20 m)
7	Key pad H85/TTD - H85/TDS (connecting to H85/DEC - H85/DEC2)	Cable 2x0,5 mm ² (max 30 m)
8	H85/DEC - H85/DEC2 (connecting to control unit)	Cable 4x0,5 mm ² (max 20 m) The number of conductors increases when using more than one output contact on H85/DEC - H85/DEC2
9	Gate open indicator Power supply 24V ⁻⁻⁻ 3W max	Cable 2x0,5 mm ² (max 10 m)
10	Courtesy light (Potential free contact) Power supply 230V~ (100 W max)	Cable 2x1 mm ² (max 20 m)

(*) The two LNA, LNB connection cables are dedicated to serial communication and may have a reduced section compared with the two +36V and 0V used to power the motor.

For LNA (green cable), LNB (blue cable): 0.5mm² (max 10m); 1mm² (max 30m)



SUGGESTIONS: with existing installations, we recommend checking the cross section of the cables and that the cables themselves are in good condition.

5.2 Electrical connections

A switch or an omnipolar cut-off switch with a contact opening of at least 3 mm must be installed on the mains power line; put the cut-off switch in OFF position and disconnect any buffer batteries before performing any cleaning or maintenance operations.

Ensure that an adequate residual current circuit breaker with a 0.03 A threshold and a suitable overcurrent cut-out are installed upstream the electrical installation in accordance with best practices and in compliance with applicable legislation.

For power supply, use a H07RN-F 2G1.5 type electric cable and connect it to the terminals L (brown) and N (blue), located inside the control panel box.

Strip the insulation from the ends of the power cable wires which will be connected to the terminal (fig. 1-2), and secure the cable with the cable retainer.

Measure the voltage on the primary mains power connection with a tester.

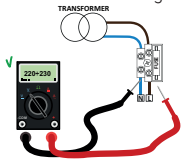

For the Brushless automation system to function correctly, the mains power voltage must be:

- 230V ~ ±10% for the F70/IPU36 control unit.

- 115V ~ ±10% for the F70/IPU36/115 control unit.

If the detected value does not comply with the above specified values or is not stable, the automation system may NOT operate efficiently.

i Connections to the electrical distribution network and to any other low-voltage conductors in the external section to the electrical panel must be on an independent path and separate from the connections to the command and safety devices (SELV = Safety Extra Low Voltage).

Make sure that the mains power conductors and the accessory wires (24V DC) are separated.

The cables must be double insulated, strip them near the relevant connection terminals and lock them with clamps (not supplied).

	DESCRIPTION
	Mains power supply 230V ~ ±10% 50 Hz connection. (115V ~ ±10% 60Hz). Fuse T2A.
	Secondary transformer input for control unit power supply; alternatively, the B71/PBX device may be used, taking care to ensure the correct polarity of the connection. NOTE: Ready wired in factory by ROGER TECHNOLOGY. NOTE: The indicated polarity applies when using B71/PBX (with external batteries) as power supply
	Connection MOTOR 1 - ROGER BRUSHLESS WITH ON-BOARD INVERTER (RS485) Check the connections illustrated in fig. 1. ⚠ The connection of the control unit to the motor must be carried out without mains/battery supply.
	Connection MOTOR 2 - ROGER BRUSHLESS WITH ON-BOARD INVERTER (RS485) Check the connections illustrated in fig. 1. ⚠ The connection of the control unit to the motor must be carried out without mains/battery supply.
	Connection to B71/BCIPU (see fig. 7) ⚠ If the battery connection is reversed, the BATT LED lights up: disconnect it immediately and correct the error. i See instructions for B71/BCIPU for further information. Only for certain types of automation systems (e.g.: SL/180/R) a power resistor must be connected to terminals 5, 6 (the value is specified in the instructions manual of the automation system) to limit the braking voltage peaks; failure to do so can result in damage to F70/IPU36 or to the F70/INV36/1 inverter in the automation system.









6 Commands and Accessories



If not installed, safety devices with NC contacts must be jumpered at the COM terminals, or disabled by modifying the parameters 50, 51, 53, 54, 73 and 74.

KEY:
N.A. (Normally Open).
N.C. (Normally Closed).

CONTACT	DESCRIPTION
19(COR) 	18 Output (potential free contact) for connecting courtesy light. 230V~ 100 W - 24 V~/--- 40 W (fig. 3).
19(COR)	18 Error alert contact only, for: <ul style="list-style-type: none"> • control unit in alarm / battery supply error (low battery); • gate completely open / gate completely closed (fig. 3). The COR output operating mode is managed by parameter 18. The battery level alert can be set-up via parameter 85.
15(+LAM) 	17(COM) Connection for flashing light (24V--- duty cycle 50%) (fig. 2). The settings for the pre-manoeuve flashing warning signal may be selected with parameter 85, while the flashing mode is set with parameter 78.
16(+ES) 	15(COM) Input for connecting electric lock, 12V--- max. 15 W (fig. 2). The function of the electric lock is determined by parameter 28 - 29. Vmedia=12V---, Vmax=40V---, see table "PRODUCT TECHNICAL FEATURES" on page 69
20(+24V)	21(COM) Power feed for external devices; see table "PRODUCT TECHNICAL FEATURES" on page 69 The control unit includes an electronic limit on the current that may be supplied to the accessories (like the SC output), this means that, in the event of an overload (or short circuit) the power supply is disabled for a few seconds (the message 24 V OFF appears on the display), after which it is restored. This situation should be avoided as there is an irregular and abnormal operation of the automation system and in the long run it can damage F70/IPU36.
22(SC) 	23(COM) Connection for gate open indicator lamp. 24V--- 3 W (fig. 2). The function of the indicator lamp is determined by parameter 88.
22(SC) 	23(COM) Photocell test connection and/or battery saving (fig. 5 and 6). It is possible to connect the power supply of the photocell transmitters (TX) to terminal 22(+SC) . Set the parameter 88 02 to enable the test function. Each time a command is received, the control unit switches the photocells off and on to check that the contact changes state correctly. Power feeds for all external devices may be connected to reduce battery consumption (if batteries are used). Set 88 03 or 88 04. WARNING! If contact 22(SC) is used for the photocell test function or battery saving function, a gate open indicator lamp cannot be connected.
24(FT2) 	23(COM) Input (N.C. or 8.2 kOhm) for connecting photocells FT2 (fig. 4-5-6). The photocells FT2 are configured by default with the following settings: <ul style="list-style-type: none"> - 53 00. Photocell FT2 disabled when gate is opening. - 54 00. Photocell FT2 disabled when gate is closing. - 55 01. The gate opens when an open command is received if photocell FT2 is obstructed. - 57 00. NC (normally closed) incoming contact. If the photocells are not installed, jumper the terminals 24(FT2) - 23(COM) or set the parameters 53 00 and 54 00. WARNING! Use R90/F4ES , G90/F4ES or T90/F4S series photocells.
25(FT1) 	23(COM) Input (N.C. or 8.2 kOhm) for connecting photocells FT1 (fig. 4-5-6). The photocells FT1 are configured by default with the following settings: <ul style="list-style-type: none"> - 50 00. Photocell triggers only during gate closure. Photocell is ignored during gate opening. - 51 02. Movement is reversed if the photocell is triggered during gate closure. - 52 01. The gate opens when an open command is received if photocell FT1 is obstructed. - 57 00. NC (normally closed) incoming contact. If the photocells are not installed, jumper the terminals 25(FT1) - 23(COM) or set the parameters 50 00 and 51 00. WARNING! Use R90/F4ES , G90/F4ES or T90/F4S series photocells.

CONTACT	DESCRIPTION
26(COS2) 28(COM) 	Input (NC or 8 kOhm) for connecting sensing edge COS2 . The sensing edge is configured by default with the following settings: - 74 00. The sensing edge COS2 (NC contact) is disabled. If the sensing edge is not installed, jumper the terminals 26(COS2) - 28(COM) or set the parameter 74 00.
27(COS1) 28(COM) 	Input (NC or 8 kOhm) for connecting sensing edge COS1 (fig. 2). The sensing edge is configured by default with the following settings: - 73 03. If the sensing edge COS1 (NC contact) is enabled, the gate always reverses. If the sensing edge is not installed, jumper the terminals 27(COS1) - 28(COM) or set the parameter 73 00.
29(ST) 28(COM) 	STOP command input (N.C. or 8.2 kOhm). The current manoeuvre is arrested if the safety contact opens. N.B.: the controller is supplied with this contact already jumpered by ROGER TECHNOLOGY. The contact is configured by default with the following settings: - 57 00. (normally closed) incoming contact.
30 (ANT) 31 	Antenna connector for slot-in radio receiver board. Use RG58 if an external antenna is used; maximum recommended length: 10 m. N.B.: do not make joints in cable.
33(ORO) 32(COM) 	Clock timer contact input (N.O.). When the clock function is active, the gate opens and remains open. At the end of the programmed time set with the external device (clock), the gate closes.
34(AP) 32(COM) 	Open control signal input (N.O.). IMPORTANT: persistent activation of the opening command prevents automatic reclosure; the automatic reclosure time count is resumed when the opening command is released.
35(CH) 38(COM) 	Close command input (N.O.).
36(PP) 38(COM) 	Step by step mode command input (N.O.). The function of the control is determined by parameter P4.
37(PED) 38(COM) 	Partial open control signal input (N.O.). On double leaf gate automation systems, by default, the partial opening command opens LEAF 1 completely. With single leaf swing gate installations, by default, partial opening is 50% of total opening.
RECEIVER CARD	Connector for plug-in radio receiver board. The control unit has two radio remote control functions by default: - PR1 - step mode command (modifiable with parameter 76). - PR2 - partial opening command (modifiable with parameter 77).
BATTERY CHARGER B71/BCIPU	(Fig. 7) In the absence of the mains power supply, the control unit is powered by the batteries, and the battery icon appears on the power supply display page (including the indication EXT if using the B71/PBX unit), until the mains supply is restored or the battery voltage falls below the safety threshold. The Battery Low icon appears on the display and the control unit no longer accepts commands. If mains power is lost while the gate is moving, the gate stops and then automatically resumes the interrupted manoeuvre after 2 seconds. N.B: in battery power mode, a fixed delay time of 1.5 s is applied even if delay times are disabled with parameters 25 and 26. To reduce battery consumption, the positive power feed wire of the photocell transmitters and receiver may be connected to terminal SC (see fig. 5-6). Set AB 03 or AB 04. In this configuration, the control unit disconnects power from the accessories devices when the gate is completely open or completely closed. WARNING! the batteries must always be connected to the electronic control unit in order to charge. Periodically (at least every 6 months), check that the batteries are in good working order. For more information, refer to the installation manual for the B71/BCIPU battery charger.
3 x 12V --- 4.5Ah (*) Only AGM type. (*) batteries can be stored inside the box code HT421.	

7 Function buttons and display

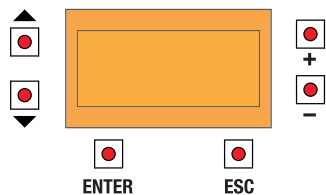

BUTTON	DESCRIPTION
▲	Returns to the display of the MENU page / moves the cursor upwards to select the MENU option
▼	Moves forwards with the display of the MENU page / moves the cursor downwards to select the MENU option
ENTER	Enters the MENU, displaying the cursor on the first option; by pressing it again, it enters the option, allowing to modify it
ESC	Exit from the menu / previous level / saving the set value
+	Value increase
-	Value decrease

When the **display is not lit up**, press any of the keys around it to reactivate the back-lighting; when it is already **lit up**, press a key to navigate the menus and activate automatic switch-off after 5 minutes.

If the display switches off (standby), press the ▲ and ▼ keys for 5 seconds to reactivate it; the image will appear again on the LCD display.

⚠ WARNING: avoid disconnecting and reconnecting the power supply, as this will cause the battery charge status information to be lost (and only recovered at the end of a complete charging cycle).

It is possible to reset to the standard factory parameters by pressing and holding the ▲ (UP ARROW) and ▼ (DOWN ARROW) keys for 4 seconds while starting up the F70/IPU36. The standard parameters can also be reset by means of parameter 90 (see description in paragraph 10.2)

8 Light signals

LED	DESCRIPTION	
BATT	<ul style="list-style-type: none"> Normally off It lights up if the battery is connected to terminals 3, 4 in reverse: disconnect it immediately and correct the error 	
L1		
L2	<ul style="list-style-type: none"> Normally off 1 slow flash: issued open command to the motors 2 slow flashes: close command issued 1 very slow flash: stop command issued On in steady state: motor timing in progress Repetitive rapid flashes: travel programming 	

9 Navigation in the menus

i **Some MENUS are for consultation only, they do not have editable options.**
In the case of the editable MENUS:

1. When you click on ENTER, the cursor will be positioned underneath the first menu item.
 2. By clicking on ▲ or the down arrow ▼ the cursor moves from one menu option to another.
 3. By clicking ENTER, the sub-menu is accessed, which in turn can have other options that can be changed or only consulted.
 4. Use the + and - keys to modify the values underlined by a cursor.
- To return to the previous level, press ESC; the value set on the the display will be saved in the memory.

10 Menù

i **The indicated data is only indicative**

10.1 Menù Welcome

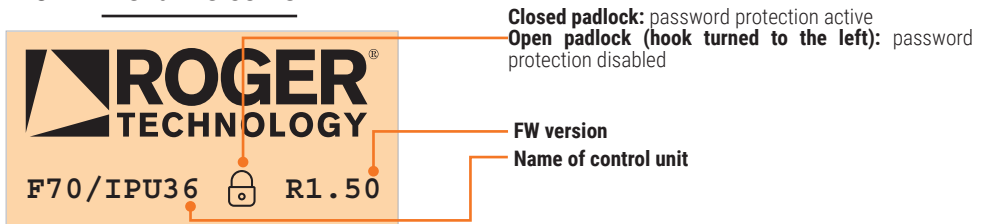

10.2 Control unit operating parameters set-up menu

i The indicated data is only indicative

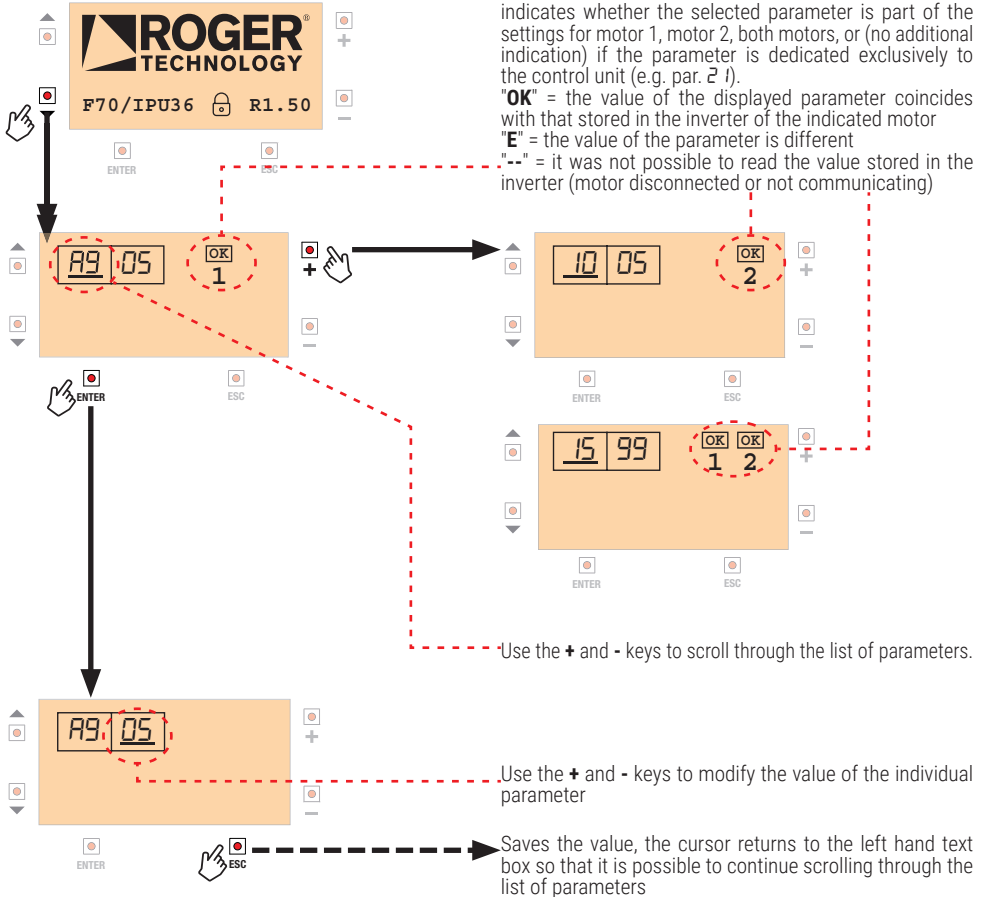

NOTE: the parameter is saved to the control unit memory and the memory of the inverter on board the motor (if the parameter in question is dedicated to it).
The destination where the parameter is saved is indicated by an icon, for example:

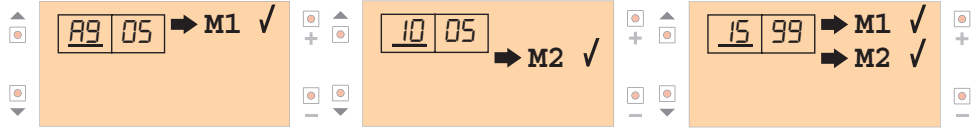

Restoring the factory default values

+ **NOTE:** this procedure is only possible if the protection password has not been set-up. The following parameters are not reset: A0, A 1, 2B, 29, 60, 6 1, 70, 7 1, 72, 86, 87.

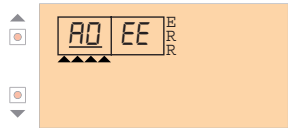
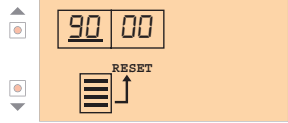

- When parameter 90 is displayed and the "+" and "-" keys are pressed and held together for 5 sec., the following icon appears on the display indicating that the parameters of the control unit have been reset to factory values; once this operation is completed, the parameters dedicated to motor 1 and motor 2 are saved in the inverters, thus obtaining the initialization of the complete system (control unit and motors) to factory values.

WARNING! Wait until the icon is extinguished (operation complete) before changing the menu page.



Parameter errors

+ The message **ERR** indicates that there is at least one error on the parameters move the cursor to the first parameter where there is an error present, identified by the letters "EE" in the field to its right.

- If the error is in the EEPROM memory of F70/IPU36, a toothed cursor appears below the box; if the error is due to a discrepancy between the value in the F70/IPU36 memory and the value in the inverter 1 or 2 memory,  or  will be displayed

The first press of the "+" (or "-") key displays the factory value; continue pressing to set the desired value. After saving the correct value, if there are any more error parameters, move onto the next one. Once all the errors have been eliminated, the message "ERR" disappears from next to the field.

To quickly return to the first parameter, briefly press the '+' and '-' buttons simultaneously.

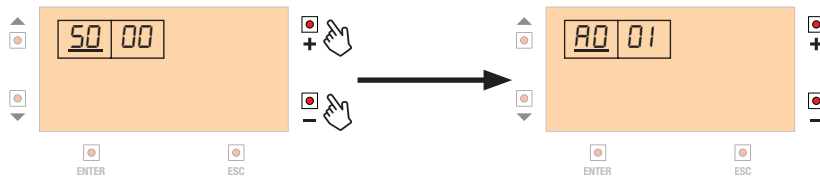

10.3 Command/safety devices/outputs status display menu

i The indicated data is only indicative

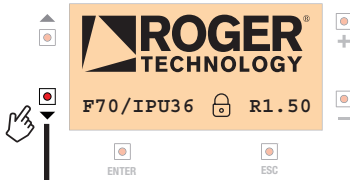

x2 click

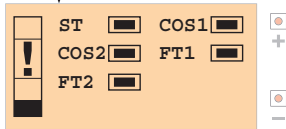
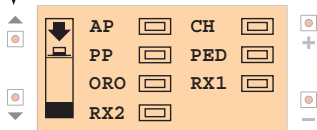

COMMAND INPUTS STATUS DISPLAY

If the corresponding panel is blacked out, it means the command is active.

SAFETY DEVICE INPUTS STATUS DISPLAY

If the corresponding panel is blacked out, it means the safety device is active and at rest; if the panel is empty, it means the safety devices is in the alarm state. If the name of the safety device is not displayed, it means it has been disabled by the respective parameter.

NOTE: depending on the type of automation system under control, the following indications may appear on this page (if managed): MOTOR 1 and MOTOR 2 aperture (FA1, FA2), closure (FC1, FC2) and release (SBL1, SBL2) limit switches.

Some types of automation may include functions managed by additional sensors, the status of which can therefore be displayed on this page, for example:

LKU: electro-latch position UP (deadbolt free)

LKD: electro-latch position DOWN (deadbolt locked).

If the total number of safety devices exceeds the 8 positions available on the page, press the "." key to scroll downwards to view the remaining positions, and the "+" key to return to the first row.

OUTPUTS INPUTS STATUS DISPLAY

If the corresponding panel is blacked out, it means the output is active; if the flashing lamp unit is activated intermittently by the control unit, then the indication on the display will be too.

LAM, ES, SC, COR are outputs of F70/IPU36; in addition, if present, there are indications of inverter-driven outputs in the motors, e.g:

LOK1 : blackened box means that the deadbolt integrated in motor 1 is powered (deadbolt unlocked).

These numbers indicate the communication status at the F70/IPU36, inverter 1 and inverter 2 levels.

If everything is normal, the numbers vary very quickly, returning periodically to 0, whereas if anything is blocked, a number other than 0 is displayed in fixed mode.

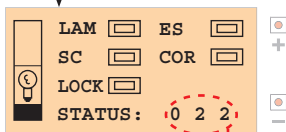

Return to the previous menu

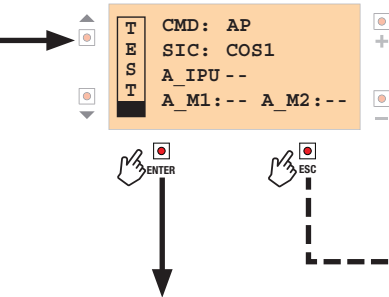

TEST MODE

Activation of a command or safety is signalled by the flashing light and warning lamp coming on (the command does not affect the automation); in the CMD line, the active command (AP, CH; ...) is highlighted for 5 seconds, while in the SIC line, the most prioritised safety is in alarm (the warning disappears when the safety returns to rest). A_IPU, A_M1 and A_M2 display an alarm number according to the tables below.

Return to the previous menu

Back to command input display

ALARMS FOR MOTOR 1 / MOTOR 2		
1	Short circuit detected on motor phases	11 No timing data in the inverter EEPROM memory, or corrupted: motor timing required
2	Motor overload detected	12 Encoder error 1: no communication with encoder
3	Motor supply voltage too low detected	13 Encoder error 2: transient error (not serious)
4	Thermal motor protection activation	14 Encoder error 3: serious error, it is necessary to disconnect the motor cable (4-wire) from the control unit, wait 10 seconds and then connect it again, checking that the alarm has disappeared
5	Motor overtemperature detected	15 Motor rotor locked (timing impossible)
6	Loss of motor control detected, if it occurs again, motor timing will be necessary	16 Motor timing failed, rotor position measurement out of tolerance
7	Calibration error in the motor current control. NOTE: the alarm is critical and does not allow automatic reset of inverter functionality. Contact service	17 Encoder magnet missing or damaged; inverter not correctly positioned or secured on the motor
8	EEPROM damaged	18 Motor data incompatibility between inverter and F70/IPU36 detected, contact service
9	EEPROM error on stroke length	19 Motor model selection is incorrect (model not managed by the inverter)
10	EEPROM error on current mapping	20 Motor faulty or motor phases not connected

ALARMS F70/IPU36		
1	No communication with inverter 1	5 Very low supply voltage
2	No communication with inverter 2	6 Overload on braking resistor circuit
3	No communication with inverter 1 and 2	7 Mains frequency fault
4	Output overload 24V	

10.4 Gate position and INFO values display menu

i The indicated data is only indicative

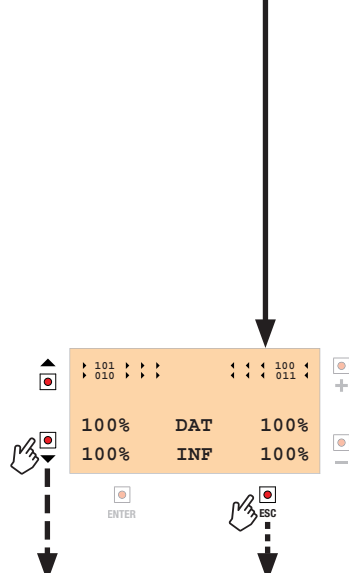
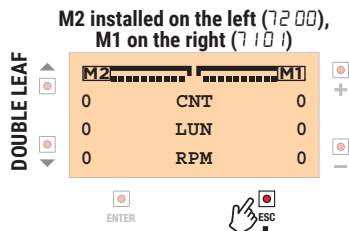
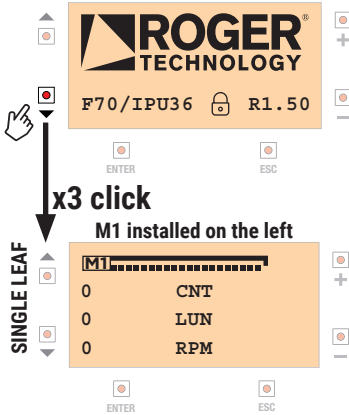

Return to the Welcome menu

Return to the previous menu

If the motor values are not read correctly during the initial automation system start-up phase (following switch-on) the message "----" is display in place of the values. the icon M1 (and M2 in the case of double gate installations) is displayed in the part (left/right) corresponding to the selected parameter: 71 or 72.

SINGLE GATE CONFIGURATION (par.70=01): the INFO values supplied by MOTOR 1 (CNT, LUN, RPM, ...) appear in the part of the display below the icon M1. Use the + or - to scroll through the list of INFO values, which are always displayed in groups of three.

M1 ██████████ **LEAF CLOSED**

M1 ██████████ **LEAF OPEN**

DOUBLE LEAF CONFIGURATION (par.70=02): the INFO values supplied by MOTOR 1 (CNT, LUN, RPM, ...) appear in the part of the display below the icon M1, while the INFO values supplied by MOTOR 2 appear below the M2 icon. Use the + or - to scroll through the list of INFO values, which are always displayed in groups of three.

M2 ██████████ **M1** ██████████ **LEAVES CLOSED**

M2 ██████████ **M1** ██████████ **LEAVES OPEN**

The list of INFO values associated with the motors is followed by the list of summary values for the F70/IPU36 unit:

- IPUBUS motors power supply voltage
- IPUAMP current drawn by the motors
- IPU_ST digital status of the automation system
- IPU_UP -- position of both motors known
 - 1- position M1 unknown
 - 2- position M2 unknown
 - i2- position of both motors unknown
- IPU_OC -E fully closed
 - EL closing
 - OP opening
 - O fully open
- IPU_UF U- voltage value too low
 - F excess current drawn by motors

This page displays information on the quality of the RS485 communications between the F70/IPU36 and the inverter modules on board the motor.

The percentage of successfully transmitted motor operating data messages is indicated next to the DAT icon (100 = no communication errors), while the figure corresponding to the INFO data messages appears next to the INFO icon.

A persistently low value indicates the presence of communication issues, and if this occurs it is advisable to check the quality of the connection cable, its cross section and the way it is routed.

10.5 Alarm display menu

i The indicated data is only indicative

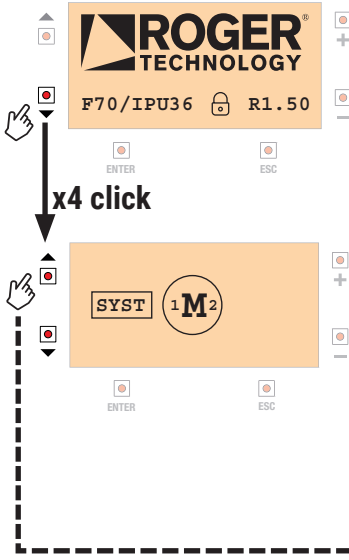

The status of MOTOR 1 is displayed to the left of the motor icon, while the status of MOTOR 2 (if present) is displayed to the right.



























When it is switched on, the first thing the F70/IPU36 does is read the data from the connected motors, collecting information about them and how they are managed (parameters, types of safety devices they are used to control).

This phase is split into two stages:

- reading the system parameters (SYST on display)
- reading the information about the data exchanged (INFO on display).

If everything functions correctly, this phase takes about 1 second, after which the message PASS; on the other hand, if any alarms are active, the respective icons are displayed.

10.5.1 Error alarms

ALARM	DESCRIPTION	ALARM	DESCRIPTION
	Short circuit detected on motor phases		Encoder error 2: transient error (not severe)
	Overload detected on motor		Encoder error 3: severe error, disconnect the (4 way) motor cable from the control, wait for 10 seconds then reconnect it, check whether the alarm has been cancelled
	Overheating detected on motor		Encoder error 4: magnetic position measurement error, magnet damaged or unstable
	Motor thermal cut-out tripped		Calibration data absent from the inverter EEPROM memory, or corrupt: execute motor calibration procedure
	Motor malfunction or motor phases not connected		Motor calibration procedure failed, rotor position measurement out of tolerance
	Motor power supply voltage too high		Encoder magnet absent or damaged; inverter not positioned correctly or not secured to motor
	Motor power supply voltage too low		Motor rotor blocked (cannot perform calibration procedure)
	Collision detected		Data error detected in the EEPROM of the inverter on board the motor
	Loss of motor control detected, execute motor re-calibration procedure		Position unknown, repositioning phase in progress
	Calibration error in motor current check NOTE: this is a critical alarm that prevents the inverter functions from being restored automatically when active. Contact Customer Service.		No communication with inverter 1
	Activation of the voltage limiter (external power resistor connected between terminals 5 and 6)		No communication with inverter 2
	Overload detected on the voltage limiter (resets after 5 seconds)		Motor model selection error (model not compatible with the inverter)
	Encoder error 1: no communication with encoder		Error detected on the motor technical board, contact Customer Service

To reset the alarm, press the ENTER key: the alarm icon is flashing. If more than one alarm icon is on, the flashing cursor can be moved using the ▲ and ▼ keys. Pressing ENTER displays the alarm category (MEMORY ALARM, ENCODER, INVERTER) and its summary description.

Press the " key: If the alarm can be cancelled, the icon will turn off and the PASS text will return, otherwise the alarm conditions persist.

In the event of an alarm condition, the screen with one of the following possible indications appears on the display at regular intervals:

- **INV.FW 1** or **INV.FW 2** or **INV.FW 1-2**: incompatibility detected between F70/IPU36 and F70/INV36/1 (respectively: inverter 1, inverter 2 or both): consult IFW information in the IDVER information menu (par. 10.17). This situation can limit functions or even block the automation system and can occur if different versions of F70/IPU36 and F70/INV36/1 are connected. The solution is to upgrade the firmware of either, using B74/BCONNECT.

- **ALARM** or **WARNING**: the alarm page appears on the display at regular intervals so that the operator can see which alarm/warning icon is active.

- **M. RELEASE**: if the automation system includes management of the release contact, opening the handle will prevent the automation system from starting; it is possible to view the status of the release on the safety device display page.

- **SEL.MOT**: indicates that the motor selected on F70/IPU36 does not correspond to that saved in the inverter memory, therefore F70/IPU36 is in the forced STOP state (it is not possible to start the automation system). Set the correct value of par. *RD* (or *A I*).

- **24V OFF**: indicates that the 24 V output overload protection has tripped (voltage is cut off at the terminal for a few seconds).

When the page containing these indications is displayed, pressing EXIT closes this menu so that the alarm no longer appears while the operator continues to scroll through the page (using the keys around the display); the alternating display mode resumes 10 seconds after the last key is activated, thereby drawing the operator's attention to the active alarm.

10.6 Control menu

i The indicated data is only indicative

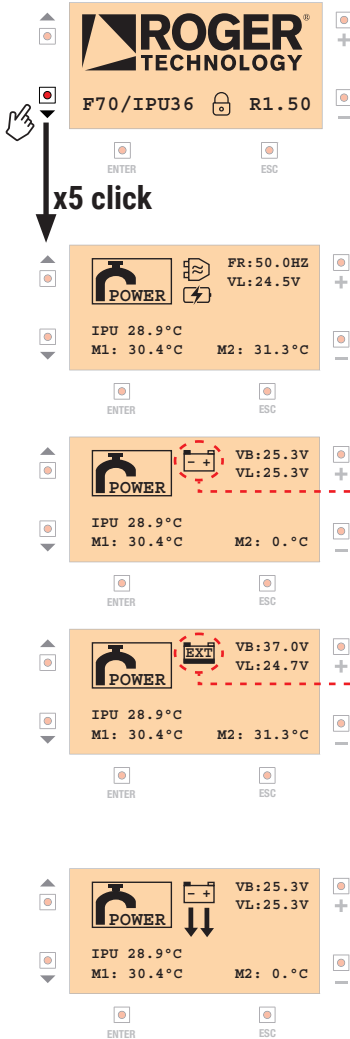

FR= mains frequency
VL= voltage supplied to +24 V output. If the overload protection has tripped this field displays the message OFF

This field displays the temperature measured on control unit (F70/IPU36) and the inverters (M1, M2).

This icon is displayed when battery charging is active: only if the mains voltage is present, the battery charged **B71/BCIPU** is enabled and the battery is connected to terminals 3-4.

The icon flashes at regular intervals to indicate the activity is in progress; the icon disappears if the battery is disconnected.

Battery operation (charging) if a battery is connected to terminals 3,4 of F70/IPU36 with battery charger enabled.

Battery low
(under the threshold set at par. B5)

External battery operation (B71/PBX36 connected to power supply terminals 1,2, instead of transformer secondary).

External battery low
(under the threshold set at par. B5)

In case of battery operation with a battery that is too low, when the motors are running a high current consumption is detected and the symbol is displayed: this means that the control unit will maintain operation for maximum 10 seconds. If the situation persists, the battery will be disconnected.

The control unit will return to operation with mains voltage or 36 V battery voltage.

If the battery voltage drops below the critical level (attainable if par. B5 is set to , so no battery saving management), symbol is displayed and the control unit no longer accepts any controls until the battery voltage rises to 36 V.

10.7 Settings menu

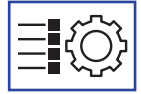

i The indicated data is only indicative

EN

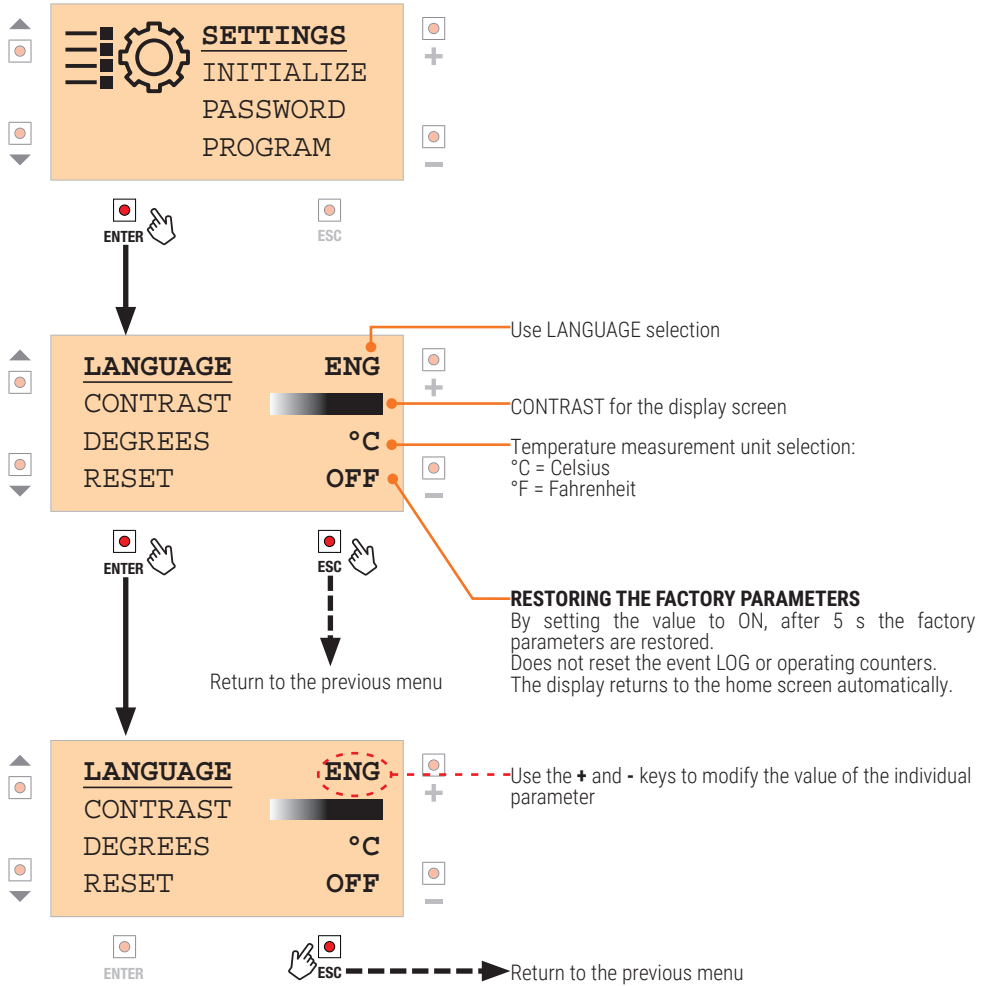

To see/modify the other functions, move onto the one required (using the ▼ and ▲ keys) and repeat the same procedure.

10.8 Emergency initialisation menu

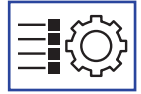

i The indicated data is only indicative

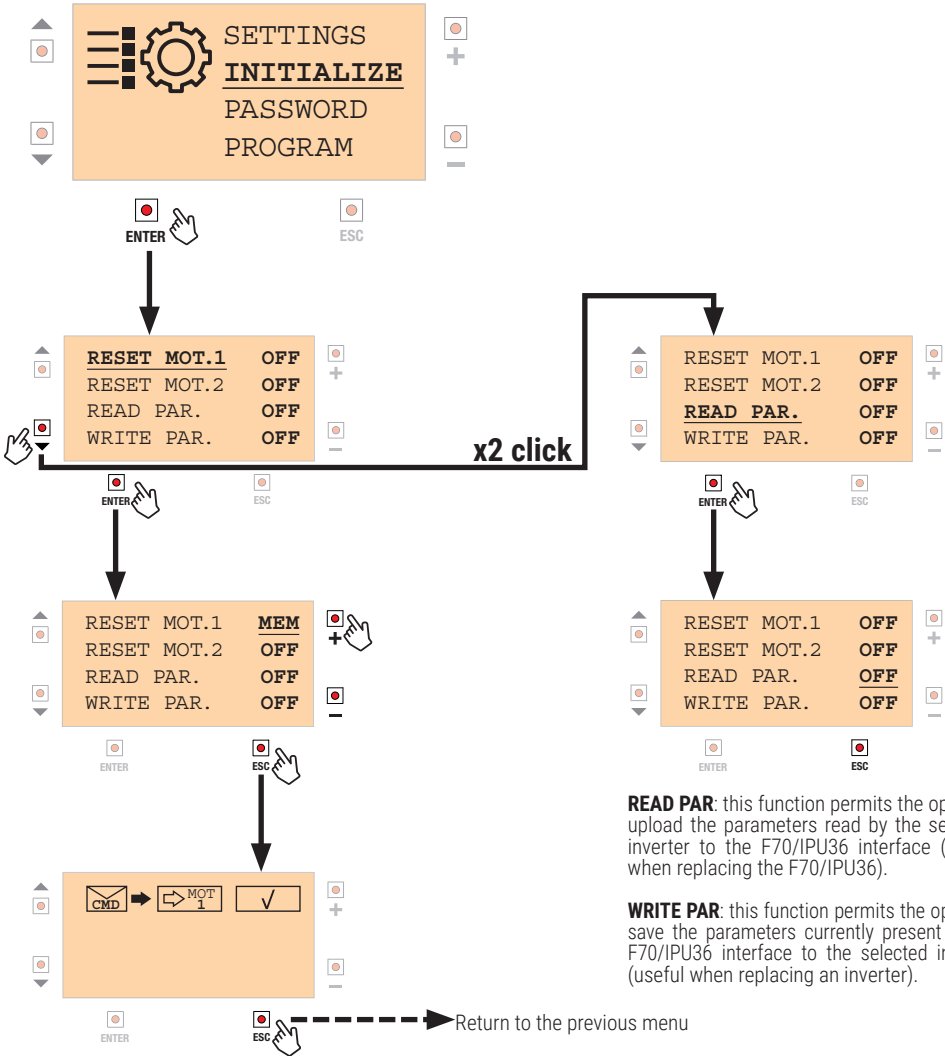

READ PAR: this function permits the operator upload the parameters read by the selected inverter to the F70/IPU36 interface (useful when replacing the F70/IPU36).

WRITE PAR: this function permits the operator save the parameters currently present in the F70/IPU36 interface to the selected inverter (useful when replacing an inverter).

- Press ENTER to position the cursor under the selected OFF, and then use the "+" and "-" keys to select the following functions:
- **MEM:** this option resets the memory of the selected inverter; it will be necessary to program the travel.
 - **PAR:** this option resets the parameters associated with the selected inverter to their factory values (the parameter that selects the motor model is not reset). After carrying out this operation, there may be some discrepancies between the parameters managed by the F70/IPU36 interface and those associated with the inverter (the message PARAMETERS appears on the display)
 - **CNT:** this option resets the system counters (number of maneuver, working hours, days switched on)
 - **BTL:** this option resets the backup information regarding the connected inverters and should only be executed when replacing the inverters and only if requested by Customer Service.
 - **BKY:** resets backup information on connected B73/KEYS keyboards
- Press EXIT to activate the initialisation described above on the selected inverter, pressing the send command followed by the confirm execution icon.

EN

10.9 Password menù

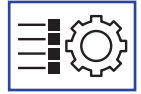

i The indicated data is only indicative



Password ON activation state

To access the **F70/IPU36** adjustments (parameter settings, travel programming, motor calibration, inverter reset) enter the password as indicated in the RELEASE PASSWORD paragraph.

With Password ON, the display will show the two rows with #####

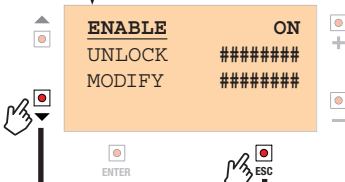

Return to the previous menu

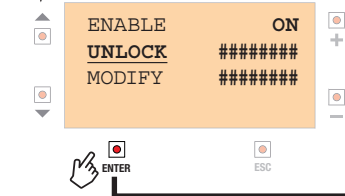

Password OFF activation state

If it is set to OFF, it is not necessary to enter the password to access the **F70/IPU36** settings

i If you want to protect the settings with a Password, proceed as indicated in the "Password modification/storing" paragraph.

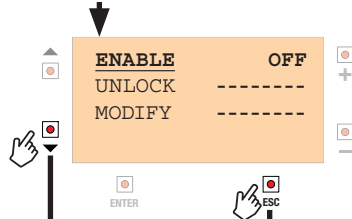

x2 click

Return to the previous menu

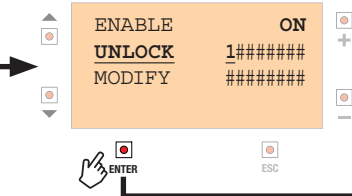

Password unlock

If the protection is activated (ON), the password must be entered to access the settings.

The cursor is positioned on the first digit on the left. Use the plus + and minus - keys to increase the number from 0 to 9. Press ENTER to move one figure to the right; when you reach the last figure, you must confirm with ESC. In the event of a mistake, repeat the process from the start.

Confirm the menu with **ESC**.

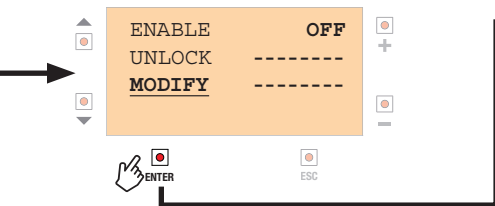

Password modification/storing

The factory password is set to 00000000 and it is equivalent to "protection OFF".

To change the PASSWORD, go to "MODIFY", press ENTER and proceed with the entry as indicated in the UNLOCK menu.

NOTE: the Password has a fixed length of 8 digits. Unmodified digits are kept as zero.

WARNING: the password is stored but the parameter settings remain accessible. After 30 minutes without using the keys, the protection will be activated automatically (ENABLE = ON).

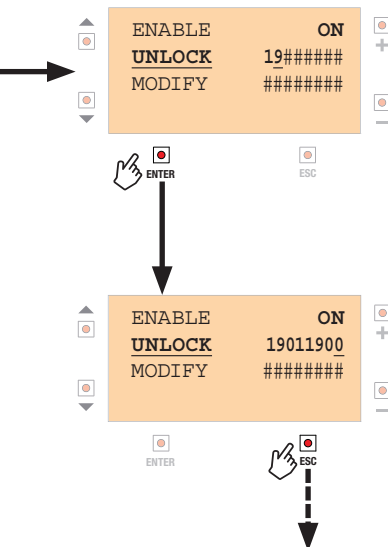

Confirm and return to the previous menu

The cursor moves on the second digit. With the plus + and minus - keys the number is increased from 0 to 9.

And so on until the desired password is completed. Confirm the number with **ENTER**. The unchanged numbers are all at 0.

When the password entered is the desired one, confirm with the key **ESC**.

NOTE: if the password entered is correct, instead of "00000" will appear "-----"

To exit the procedure press key **ESC**.

10.10 Travel acquisition menu / motor calibration

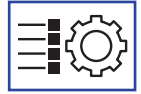

i The indicated data is only indicative

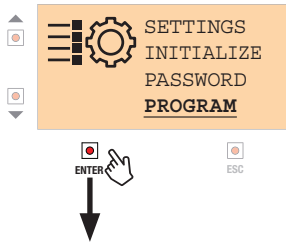

The **AUTOPROG** menu provides a step-by-step guide to programming the automation system through a series of display messages and an automatic check procedure (or, if necessary, manual actions on the part of the programmer, for example, activating the release).
The **CALIBRATION** and **TRAVEL ACQUISITION** menus may be used to execute the calibration/travel acquisition function on one the selected motor.

NOTE: "calibration" is the calibration of the operation of the encoder circuit, integrated into the motor inverter.

ATTENTION! Before proceeding, read section 17 carefully: of these menus under normal conditions only TRAVEL ACQ.

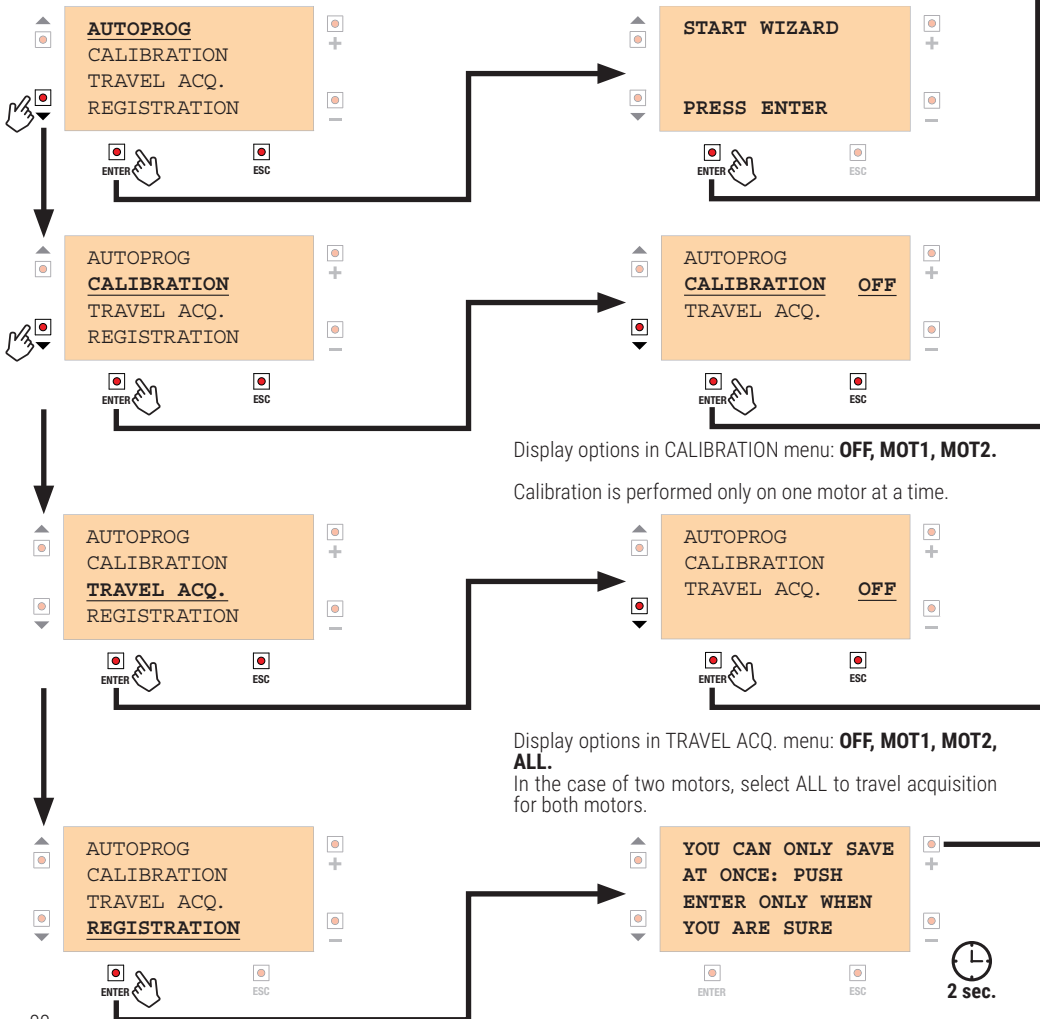

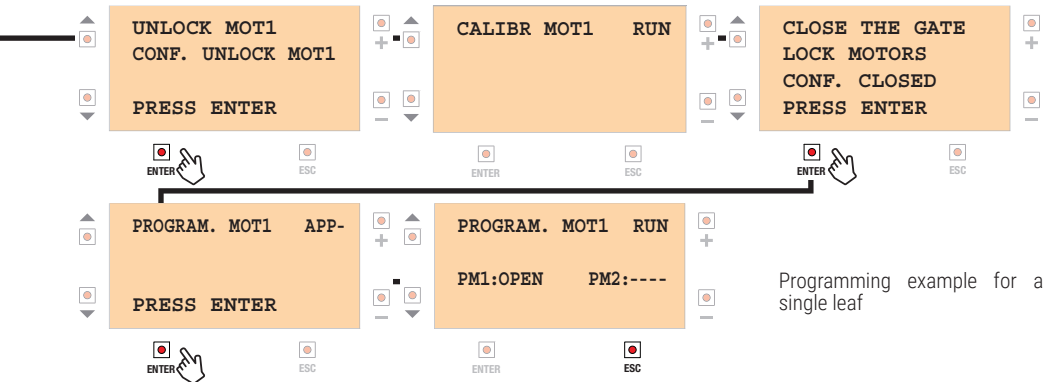

Programming example for a single leaf

Once programming is complete the message **RUN** is replaced by the message **PASS** (if the process was completed successfully) or **FAIL** if it failed.

PM1 = Programming Motor 1
PM2 = Programming Motor 2
 If only one motor is being programmed, the other one displays "----"

Display options in PM1 / PM2 menu: **OPEN** (OPENING), **PAUS** (PAUSE), **CLOS** (CLOSING), **PASS** (programming OK), **FAIL** (programming failed).

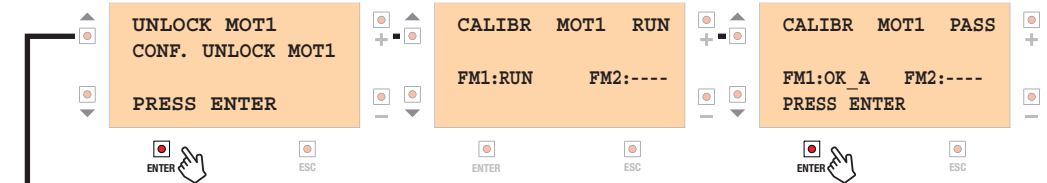

FM1 = Calibration Motor 1
FM2 = Calibration Motor 2
 The calibration procedure may result in two successful outcomes **OK_A** (successful at first attempt) or **OK_B** (blocked rotor detected at first attempt, rotation impossible, hence reverse rotation executed). **OK_B** indicates that it was not possible to release the motor or there were problems activating the rotor.

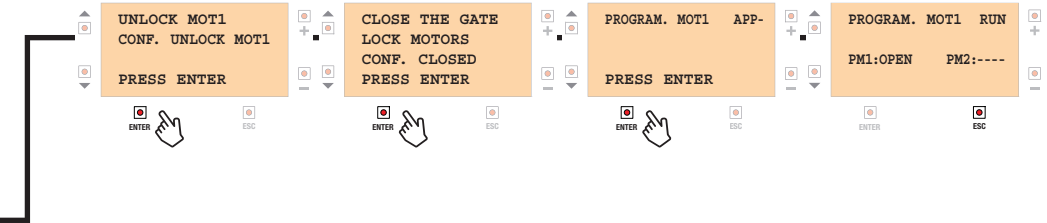

Pressing ESC exits the menu without saving anything

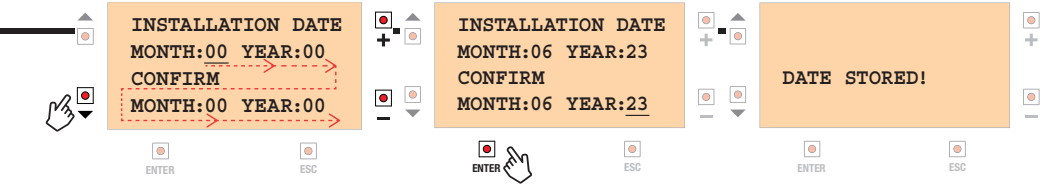

10.11 SERIAL communication menu



i The indicated data is only indicative

The **SERIAL** menu may be used to enable the WIFI connection in order to use the B74/BCONNECT module; to do this, it is necessary to enable communications and select the TARGET B-CONN.

EN

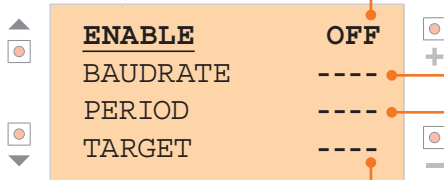
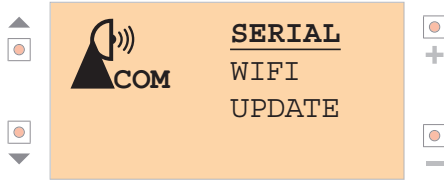

ON = serial communication enabled
 OFF * = serial communication disabled
 (*) Make sure it's always set to OFF

BAUDRATE
 Selection of the communication **BAUDRATE**.
 Selectable values: 9600, 19200, 38400, 57600, 115200

PERIOD
 Selection of the time interval for sending data, in seconds (frequency of LOG events).
 Selectable values: OFF, 5 s, 15 s, 30 s, 1 min, 5 min, 30 min.

B-CONN Enable B74/BCONNECT (fixed baud rate: 115200)

DEBUG Enable calibration device (for ROGER only, fixed baud rate 3Mbps)

PCLOG Enables LOG data to be sent to a PC, adjustable baudrate (for future use)



Return to the previous menu

10.12 WiFi menu (with B74/BCONNECT)



i The indicated data is only indicative

By connecting the Roger B74/BCONNECT module to the F70/IPU36 **WiFi** connector, it is possible to update the Firmware for the F70/INV36/1, or the two inverter modules on board the motor (having activated the UPDATE menu first), as well as consulting several measurement values using the WEB application.

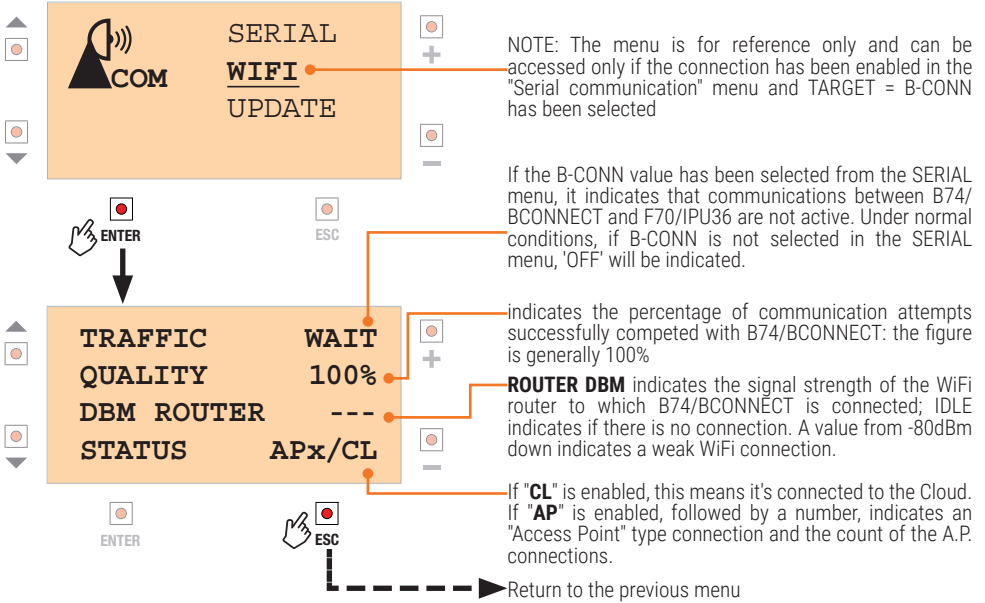

EN

10.13 Update menu (FW inverter update / accessories)

i The indicated data is only indicative

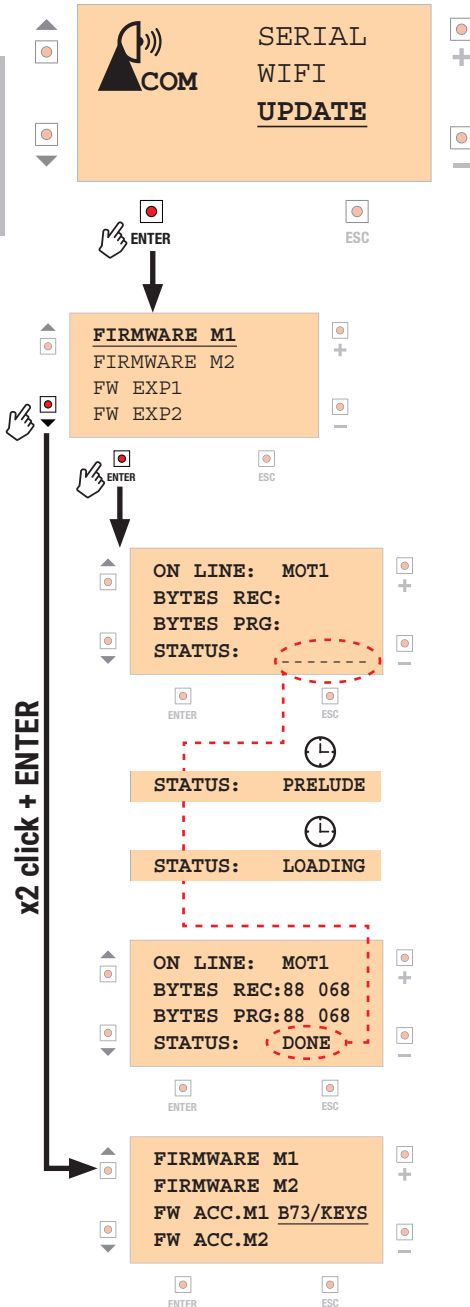

It allows the firmware update of the inverters on board the motor (FIRMWARE M1, FIRMWARE M2), or of the accessories connected to connectors EXP1 (FW EXP1) or EXP2 (FW EXP2).

The firmware update is possible by exploiting the potential of the B74/BCONNECT device on which the firmware dedicated to the inverters or accessories must be downloaded in advance.

Proceed as follows:

- 1) Select the device on which you wish to perform the update, pressing ENTER: on the FIRMWARE M1 or FIRMWARE M2 menus you will enter the page dedicated to data communication. If, on the other hand, the FW update of accessories is chosen, a selection menu opens with which the accessory to be updated can be chosen.
- 2) After executing point 1, access the WEB application page from the dedicated FW update menu.
- 3) Start the update procedure by selecting the command APP B74/BCONNECT.

The following indications appear on the display in sequence (see display on the left).

NOTE: if the procedure is not successful at the first attempt, repeat until the desired result is obtained. In the event of an anomaly, the programming sequence may be interrupted once it has started; if so, the correct operation of the inverter will be compromised until such time as the procedure has been completed (the two red and green LEDs of F70/INV36/1 flash alternately, the automation system is blocked until the firmware update is complete).

To perform the firmware update (example) of motor 1 (or motor 2) without opening the control unit, you can proceed as follows:

- 1) Select parameter **B9**, FUNCTIONALITY category, in the B-CONNECT application and set value 01 (motor 1) or 02 (motor 2); this brings F70/IPU36 to the UPDATE M1 (UPDATE M2) menu
- 2) perform the firmware update as indicated above, via the APP
- 3) once the update is completed, set parameter **B9** to **00**: this will reset the control unit and will load data from the motors: operation resumes, the automation system must perform a repositioning cycle (the reset causes position to be lost).

NOTE: Setting parameter **B9** to value **03** will upgrade B73/KEYS connected to EXP1, setting **04** B73/KEYS connected to EXP2.

10.14 Counters menu



i The indicated data is only indicative

i	COUNTERS	
	EVENTS	+
	TIMES	
	IDVER	-



TARGET	IPU	
MANEUVER	00000052	+
WORK. HOURS	000001	
DAYS ON	0000	-

TARGET: indicates which device the below data are being read from
MANEUVER: number of maneuver (number of openings executed).
WORK. HOURS.: automation system operating hours, with motors active.
DAYS ON: days with control unit switched on.



Return to the previous menu

TARGET	IPU	
MANEUVER		+
WORK. HOURS		
DAYS ON		-

With '+' and '-' you can select the options:
 MOT1 (motor inverter 1)
 MOT2 (motor inverter 2)
 KEY1 (B73/KEYS connected to EXP1)
 KEY2 (B73/KEYS connected to EXP2)



TARGET	MOT1	
MANEUVER		+
WORK. HOURS		
DAYS ON		-

Pressing ESC displays the data for the selected target. Pressing ESC at this point takes you to the main COUNTER page.



TARGET	KEY1	
MANEUVER		+
WORK. HOURS		
DAYS ON		-

NUM. AP:	0000000	
NUM. ST:	0000000	+
NUM. CH:	0000000	
GIORNI:	00000	-



EN

10.15 Events menu



i The indicated data is only indicative

EN

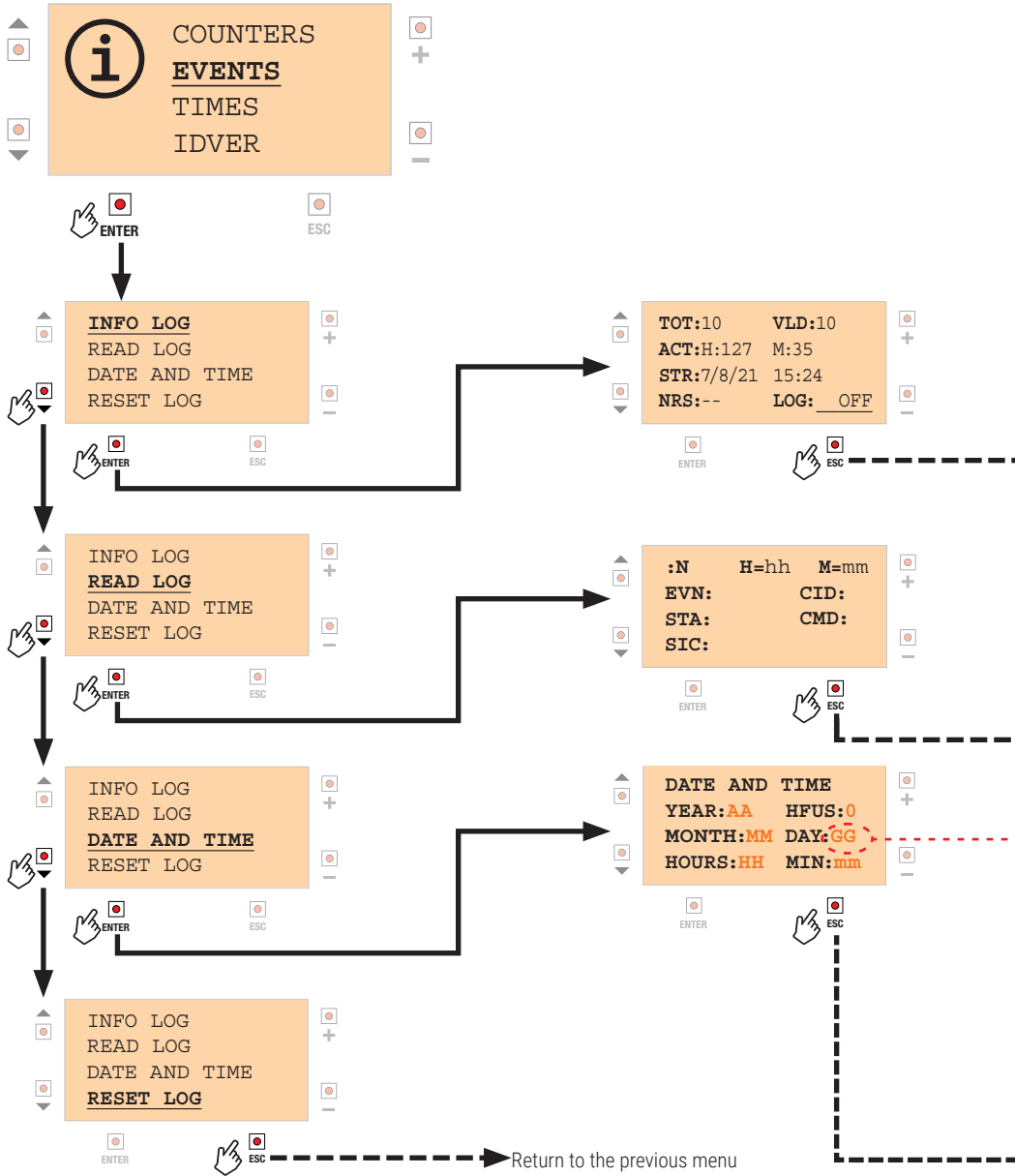

- LOG INFO:** Indicates the number of LOG events stored
READ LOG: To consult the LOG data stored
DATE AND TIME: This option may be used to save the current date and time, which will be updated by the internal clock thereafter. In the event of a prolonged blackout, there will be a lag in the system time when the mains power is restored (in the absence of automatic updates from B74/BCONNECT, if not installed on the corresponding connector).
- RESET LOG:** This function resets the LOG memory: if the value is set to ON, the message RESET appears after 4 seconds and, once the process is complete, the message #### appears the LOGS have been reset.
- TOT:** Indicates the total number of LOG events stored
ACT: Indicates the time elapsed (in hours and minutes) since the last LOG RESET was made
STR: Indicates the date and time of the last LOG RESET
NRS: Indicates the number of interruptions (resets) detected
NOTE: if the number is other than 0, the times associated with the LOG events are no longer reliable
- VLD:** Indicates the number of LOG events for which the time-stamp is certain
LOG: this field indicates the operating mode: OFF (LOG disabled), MEMO (save the LOG data to the volatile memory of the F70/IPU36 and the EEPROM, the data are retained even in the event of a blackout), BCONN (save to the volatile memory only, the backup is saved to B74/BCONNECT which must be permanently connected to F70/IPU36).

NOTE: 250 events can be saved. The 251st event will overwrite the first one, and so on.

Return to the previous menu

- :N** indicates the LOG event number (0...249)
H= indicates the hours that have passed since the first LOG event registered (*)
M= indicates the minutes that have passed since the first event (*)
EVN: type of event (CSTD: standard command (via terminal board), CRAD: radio command; CACP: Access-Point command via B74/BCONNECT, CCLD: command from Cloud via B74/BCONNECT, ALRM: alarm, SSIC: safety device, MODE activated: change operating mode).
CID: cause of the event EVN (RESET: control unit reset, L-BATT: transfer from mains to battery, BATTDW: battery discharging, BTLO: battery low, commands inhibited, B-LINE: transfer from battery to mains, U-POS: unknown position, PWDMEM: save/change password, PWDSBL: disable password protection, PWDRUN: reactivate password protection, RESETP: restore factory parameters, OP-BAT: forced opening control for low battery, CL-BAT: Forced close control for low battery).
STA: state in which the event occurred (-C: fully closed, OP: opening, OPS: stop while opening, -O: fully open CL: closing, CLS: stop while closing, IGN: unknown position).
CMD: command that caused the event (AP: opening, CH: closing, PP: step mmode, PE: pedestrian, OR: clock, R1: radio command PR1, R2: radio command PR2, RX1, RX2: uscita 1 o 2 del ricevitore ad innesto)
SIC: safety devices that caused the event (ST, COS1, COS2, FT1, FT2).
NOTE: a radio command that causes opening will be indicated with AP but CRAD will be indicated in the EVN field

Return to the previous menu

The value can be modified with the + or - keys.

Use the ▲ and ▼ keys to navigate the options (in orange) that are underlined. Press **ESC** to save the settings and return to the previous level.

HFUS: adjustment for local time with respect to UTC supplied by B74/BCONNECT, regulation -12 hours...+12 hours. Alternatively, if B74/BCONNECT is present, which accesses an NTP server and provides the time of location, it displays NTP and no time compensation is required.

NB: if the device is disconnected from the power supply (display OFF), in the absence of B74/CONNECT the last date/time (saved regularly in the EEPROM memory) will be set at the next switch-on.

Return to the previous menu

(*) NB: in H/M visualisation, you will only see the time that has passed since the first event saved in the memory. If the exact DATE and TIME are set-up in the section, F70/IPU36 is capable of converting this information into the date and time when the LOG event occurred. By clicking the ENTER button you will switch to the display of the estimated date and time for the LOG event (if B74/BCONNECT is installed, date and time are certain).

10.16 Time management menu



i The indicated data is only indicative

EN

COUNTERS

 EVENTS +

TIMES

 IDVER -

ENTER ESC

THERMAL MOT.1 +

 THERMAL MOT.2

 EXTRA TEMPERATURE

 BATT. OPERATION -

ENTER ESC

DAYS 2 +

 HOURS 2

 MINUTES 15

 SECONDS 2 RUN -

ENTER ESC

DAYS 2 +

 HOURS 2

 MINUTES 15

 SECONDS 2 STOP -

ENTER ESC

DAYS 2 +

 HOURS 2

 MINUTES 15

 SECONDS 2 RESET -

ENTER ESC

→ Return to the previous menu

THERMAL MOT.1: Total time that MOTOR 1 thermal protection has been active due to overheating.
THERMAL MOT.2: Total time that MOTOR 2 thermal protection has been active due to overheating.
EXTRA TEMPERATURE: Time for which the temperature has been outside the declared range (-20°C, +55°C).
BATTERY OPERATION: Total time the batteries have been required to provide current (of present, only if connected directly to terminals 3,4 with battery charger B71/BCIPU).

To see/modify the other functions, move onto the one required (using the ▼ and ▲ keys) and repeat the same procedure.

STOP: interrupts the count

RESET: resets the count, keeping it at zero
 To reset, press the ESC key, returning to the previous menu.

Use the - key to go back in the sequence RESET > STOP > RUN
RECOMMENDED SETTING: RUN (the count is functional)

10.17 Menù numeri seriali/versioni HW e FW



i The indicated data is only indicative

COUNTERS
EVENTS
TIMES
IDVER

+

-



TARGET: IPU R1.50

HW:2 IFW:02-03

SERN:200000 04/22

R485:1.0 BOOT:1.10

+

-

-Firmware version of the board
TARGET: indicates which device the data below are being read from.
HW: Hardware version of the board.
IFW: - if TARGET IPU: FW version requested for the inverter
 - if TARGET MOT: FW version present on motor (*)
 (*) the IFW value read by the inverter must be in the range (or equal to the value) read from F70/IPU36. Otherwise, the INV.FW alarm is triggered (par. 10.5.1)
SERN: 6-figure serial number.
 -Week/year.
R485: the version of the MODBUS protocol used for serial communication or via WiFi.
BOOT: the BOOTLOADER version (for B71/PBX firmware update).
 Return to the previous menu



TARGET: IPU R1.50

HW: IFW:

SERN:

R485: BOOT:

+

-

Use the "+" and "-" keys to select the following options: MOT1 or MOT2.



Pressing ESC returns to the main IDVER page, although those corresponding to MOT1 are displayed (if MOT 1 is selected) or MOT2 (or F70/IPU36).

EN

10.18 Alarm menu



i The indicated data is only indicative

10.18.1 General alarm

EN

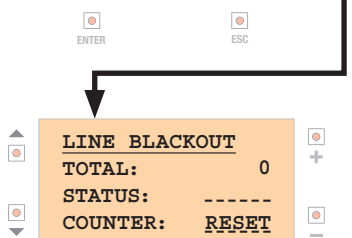
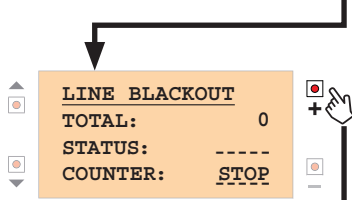
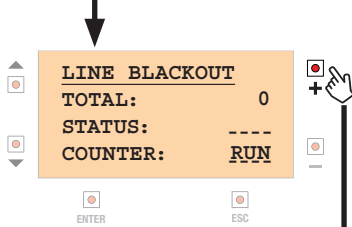
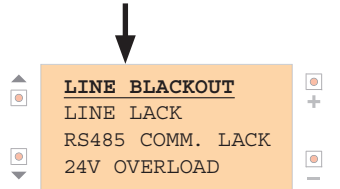
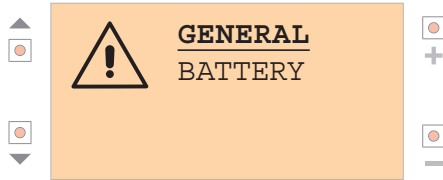

LINE BLACKOUT: Shows the number of blackouts detected in the mains voltage.

STATUS:

ON: (if no mains power)
OFF: (if there is mains power)

LINE LACK: Shows the voltage surges (gaps) detected.

STATUS:

ON: (voltage hole detected in the last 60 seconds)
OFF: (regular mains voltage)

RS485 COMM. LACK: Displays the number of communication losses

STATUS:

ON: RS485 communication absent in at least one of the two motors
OFF: RS485 communication efficient

24V OVERLOAD: Number of overloads detected on the external loads (photocells, etc.) 24 V power supply output.

STATUS:

ON: current demand too high, safety device tripped
OFF: current drawn within limits

To see/modify the other functions, move onto the one required (using the ▼ and ▲ keys) and repeat the same procedure.

STOP: interrupts the count

RESET: resets the count, keeping it at zero
To reset, press the ESC key, returning to the previous menu.

Use the - key to go back in the sequence RESET > STOP > RUN

RECOMMENDED SETTING: RUN (the count is functional)

10.18.2 Battery menu



i The indicated data is only indicative

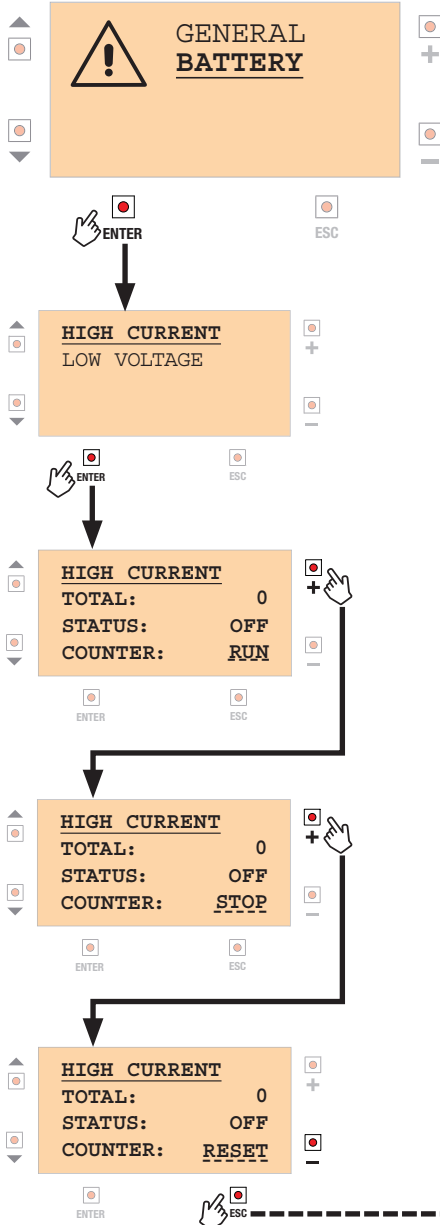

HIGH CURRENT: Displays the number of activations of the protection on the charging circuit.

LOW VOLTAGE: Displays the number of calibration errors of the current measurement circuit.

To see/modify the other functions, move onto the one required (using the ▼ and ▲ keys) and repeat the same procedure.

STOP: interrupts the count

RESET: resets the count, keeping it at zero
To reset, press the ESC key, returning to the previous menu.

Use the - key to go back in the sequence RESET > STOP > RUN

RECOMMENDED SETTING: RUN (the count is functional)

Return to the previous menu

11 Index of parameters

PARAM.	FACTORY DEFAULT	DESCRIPTION	PAGE
A0	01	Automation type MOTOR 1	103
A1	01	Automation type MOTOR 2	103
A2	00	Automatic reclosing after pause time (from fully open gate)	103
A3	00	Automatic gate closing after mains power outage (black-out)	103
A4	00	Selecting step mode control function (PP)	103
A5	00	Pre-flashing	103
A6	00	Condominium function for partial open command (PED)	103
A7	00	Enabling operator present function	103
A8	00	Gate open indicator / photocell test function and "battery saving"	104
A9	08	MOTOR 1 setting deceleration during opening	104
I0	08	MOTOR 2 setting deceleration during opening	104
I1	08	MOTOR 1 setting deceleration during closing	104
I2	08	MOTOR 2 setting deceleration during closing	104
I3	I0	Position control adjustment LEAF 1 fully open/closed	104
I4	I0	Position control adjustment LEAF 2 fully open/closed	104
I5	99	Partial opening adjustment (%)	104
I8	00	Type of signaling provided by COR output	104
I9	00	Adjusting MOTOR 1 stop advance on gate open stop	105
20	00	Adjusting MOTOR 2 stop advance on gate open stop	105
21	30	Setting automatic closing time	105
22	00	Enabling of management for opening with automatic reclosure exclusion	105
23	I0	Regulating the automatic closing time after opening pedestrian gate	105
25	03	Adjusting opening delay of MOTOR 2	105
26	05	Adjusting opening delay of MOTOR 1	105
27	03	Setting reverse time after activation of sensing edge or obstacle detection (crush prevention)	105
28	00	Select type of electric lock	105
29	00	Enable electric lock	105
30	07	Setting MOTOR 1 torque	106
31	07	Setting MOTOR 2 torque	106
32	I5	Setting obstacle impact force sensitivity MOTOR 1	106
33	I5	Setting obstacle impact force sensitivity MOTOR 2	106
34	08	Setting start acceleration MOTOR 1 during opening	106
35	08	Setting start acceleration MOTOR 2 during opening	106
36	08	Setting start acceleration MOTOR 1 during closing	106

PARAM.	FACTORY DEFAULT	DESCRIPTION	PAGE
37	08	Setting start acceleration MOTOR 2 during closing	106
38	00	Enable electric lock release reverse impulse	106
40	07	MOTOR 1 opening speed setting (%)	106
41	07	MOTOR 2 opening speed setting (%)	106
42	07	MOTOR 1 closing speed setting (%)	106
43	07	MOTOR 2 closing speed setting (%)	106
44	05	MOTOR 1 end of manoeuvre constant approach speed setting	107
45	05	MOTOR 2 end of manoeuvre constant approach speed setting	107
49	01	Setting number of automatic closure attempts after activation of sensing edge or obstacle detection (crush protection)	107
50	00	Setting photocell mode during gate opening (FT1)	107
51	02	Setting photocell mode during gate closing (FT1)	107
52	01	Photocell (FT1) mode with gate closed	107
53	00	Setting photocell mode during gate opening (FT2)	107
54	00	Setting photocell mode during gate closing (FT2)	107
55	01	Photocell (FT2) mode with gate closed	108
56	00	Enable close command 6 s after activation of photocell (FT1-FT2)	108
57	00	Selecting contact type (NC or 8.2 kOhm) on inputs FT1/FT2/ST	108
58	00	Selecting the type of photocell test on input FT1	108
59	00	Selecting the type of photocell test on input FT2	108
60	00	Enable MOTOR 1 limit switch	108
61	00	Enable MOTOR 2 limit switch	108
63	00	Enable MOTOR 1 braking	108
64	00	Enable MOTOR 2 braking	108
65	05	Setting MOTOR 1 stop distance	108
66	05	Setting MOTOR 2 stop distance	109
67	00	Enable MOTOR 1 internal electric lock	109
68	00	Enable MOTOR 2 internal electric lock	109
70	02	Select number of motors installed	109
71	01	Selecting installation position of motor relative to gate MOTOR 1 (seen from interior side)	109
72	00	Selecting installation position of motor relative to gate MOTOR 2 (seen from interior side)	109
73	03	Configuring sensing edge COS1	109
74	00	Configuring sensing edge COS2	109
76	00	Configuring radio channel 1 (PR1)	109
77	01	Configuring radio channel 2 (PR2)	109
78	00	Configuring flashing light frequency	110

PARAM.	FACTORY DEFAULT	DESCRIPTION	PAGE
79	60	Selecting courtesy light mode	110
80	00	Clock contact configuration (ORO)	110
81	00	Enable safeguarded gate closure/opening	110
82	03	Setting safeguarded closure/opening activation time	110
83	00	Selecting limitations in battery operation	110
84	00	Battery type selection and consumption reduction	111
85	00	Selection of the battery operation management	111
86	00	Enabling of regular maintenance activation	111
87	00	Adjustment of regular maintenance activation hour counter	111
88	00	Cyclical activation (test mode)	111
89	00	Activating firmware update mode for the inverters (on board the motor) or accessories	111
90	00	Restoring factory default values	111
X0	00	Enable B73/RGB connected to MOTOR 1	112
X1	00	Enable B73/RGB connected to MOTOR 2	112
X2	00	Select beacon operating mode	112
X3	00	Select RGB error alert operating mode	112
X4	00	Enabling incoming colour transition at full aperture	112
X5	00	Select RGB colour in stand-by	112
X6	00	Select the RGB lights stand-by time (when fully closed)	112
X7	00	Keyboard enabling B73/KEYS	112
Y0	10	Setting the approach space of MOTOR 1 in OPENING	112
Y1	10	Setting the approach space of MOTOR 2 in OPENING	112
Y2	10	Setting the approach space of MOTOR 1 in CLOSING	112
Y3	10	Setting the approach space of MOTOR 2 in CLOSING	112
Y4	00	Enable maximum torque boost when starting MOTOR 1	113
Y5	00	Enable maximum torque boost when starting MOTOR 2	133
Y6	00	Setting motor torque during position recovery MOTOR 1	113
Y7	00	Setting motor torque during position recovery MOTOR 2	113

12 Parameter menu

PARAMETER PARAMETER
VALUE

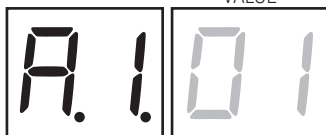

A0 00	Selecting automation system model MOTOR 1 WARNING! If this parameter is not set correctly, the automation system may not function properly. N.B.: in the event of a reset to restore the default parameters, this parameter must be set again manually.
A1 00	Selecting automation system model MOTOR 2 WARNING! If this parameter is not set correctly, the automation system may not function properly. N.B.: in the event of a reset to restore the default parameters, this parameter must be set again manually.
0 1	NV/200/DX - NV/200/SX - Motor for folding doors IRREVERSIBLE .
02	SL/180/R - Motor for pedestrian gates REVERSIBLE . 
A2 00	Automatic closure after pause time (from gate completely open)
00	Disabled.
0 1- 15	From 1 to 15 of gate closure attempts after photocell is triggered. Once the number of attempts set is reached, the gate remains open.
99	The gate tries to close indefinitely.
A3 00	Automatic gate closing after mains power outage (black-out)
00	Disabled. The gate does not close automatically when mains power is restored.
0 1	Enabled. If the gate is NOT completely open, when mains power is restored, the gate closes after a 5 second warning signalled with the flashing light (independently of the value set with the parameter A5). The gate closes in "position recovery" mode (see chapter 16).
A4 00	Selecting step mode control function (PP)
00	Open-stop-close-stop-open-stop-close...
0 1	Condominium function: the gate opens and closes after the set automatic closing time. The automatic closing timer restarts if a new step mode command is received. Step mode commands are ignored while the gate is opening. This allows the gate to open completely and prevents the gate from closing when not required. If automatic closing is disabled (A2 00), the condominium function automatically attempts a closing manoeuvre A2 0 1.
02	Condominium function: the gate opens and closes after the set automatic closing time. The automatic closing timer does NOT restart if a new step mode command is received. Step mode commands are ignored while the gate is opening. This allows the gate to open completely and prevents the gate from closing when not required. If automatic closing is disabled (A2 00), the condominium function automatically attempts a closing manoeuvre A2 0 1.
03	Open-close-open-close.
04	Open-close-stop-open.
A5 00	Pre-flashing
00	Disabled. The flashing light is activated during opening and closing maneuver.
0 1- 10	Flashing warning signal for 1 to 10 seconds prior to every manoeuvre.
99	5 second flashing warning signal prior to closing manoeuvre.
A6 00	Condominium function for partial open command (PED)
00	Disabled. The gate opens partially in step mode: open-stop-close-stop-open...
0 1	Enabled. Partial commands are ignored during gate opening.
A7 00	Enabling operator present function
00	Disabled.

01	Enabled. The open (AP) or close (CH) button must be pressed continuously to operate the gate. The gate stops when the button is released.
02	Opening is in semi-automatic mode by AP command only, operator present function for the closing by CH command at the terminal board only. PP and PED commands are ignored, either by terminal board or remote control.
88 00	Gate open indicator / photocell test function and "battery saving"
00	The indicator is off when the gate is closed, and steadily lit during maneuver and when the gate is open.
01	The indicator flashes slowly during opening maneuver, and is lit steadily when the gate is completely open. It flashes quickly during closing maneuver. If the gate is stopped in an intermediate position, the lamp extinguishes twice every 15 seconds.
02	Set 02 if the output SC is used for the photocell test. See fig. 5. NB: the type of photocell test can be selected by means of parameters 58 and 59 .
03	Set to 03 if the output SC is used for the "battery saving" function. See fig. 6. When the gate is completely open or closed, the control unit deactivates any accessories connected to terminal SC to reduce battery consumption.
04	Set to 04 if the output SC is used for the "battery saving" function and photocell test function. See fig. 6. NB: the type of photocell test can be selected by means of parameters 58 and 59 .
89 08	Setting deceleration MOTOR 1 during OPENING
10 08	Setting deceleration MOTOR 2 during OPENING
01-10	01= the gate decelerates near stops and the limit switch (if installed) ... 10= the gate decelerates long before stops and the limit switch (if installed).
11 08	Setting deceleration MOTOR 1 during CLOSING
12 08	Setting deceleration MOTOR 2 during CLOSING
01-10	01= the gate decelerates near stops and the limit switch (if installed) ... 10= the gate decelerates long before stops and the limit switch (if installed).
13 10	Adjusting LEAF 1 position control when completely opens or closes NOTE: the parameter is only visible if there are no opening/closing limit switches motor 1 The value selected must ensure that LEAF 1 is opened/closed correctly when it reaches the respective (open or closed) mechanical stop. The position of LEAF 1 is calculated by the system from the number of motor revolutions and the motor reduction gear ratio. Warning! Excessively low values cause the gate to reverse when it reaches the gate open stop.
14 10	Adjusting LEAF 2 position control when completely opens or closes NOTE: the parameter is only visible if there are no opening/closing limit switches motor 2 The value selected must ensure that LEAF 2 is opened/closed correctly when it reaches the respective (open or closed) mechanical stop. The position of LEAF 2 is calculated by the system from the number of motor revolutions and the motor reduction gear ratio. Warning! Excessively low values cause the gate to reverse when it reaches the gate closed stop.
01-30	Motor revolutions (01 = minimum / 30 = maximum).
15 99	Partial opening adjustment (%) N.B.: with double leaf swing gate installations, this parameter is set by default as the completely open position of LEAF 1. With single leaf swing gate installations, this parameter is set to 50% of total opening.
15-99	From 15% to 99% of total gate travel.
18 00	Type of signaling provided by COR output
00	STANDARD operation managed by parameter 79.
01	Contact closed if the control unit is working properly. Contact open if central locked in alarm.
02	Contact closed if the control unit is powered by the mains or charged battery. Open contact due to a fault: control unit powered by low battery (voltage level set by par. 85) or with error alert BELO (the control unit no longer accept commands).
03	Closed contact if none of the fault related situations 1 and 2 occurs. Open contact if at least one of the fault related situations 1 and 2 occurs.
04	Closed contact if the gate is not completely open. Open contact if the gate is completely open.
05	Closed contact if the gate is not completely closed. Open contact if the gate is completely closed.

19 00	Adjusting stop advance of MOTOR 1 when opening
20 00	Adjusting stop advance of MOTOR 2 when opening
00	The leaf stops against the opening stop.
0 1-25	A leaf stop advance of 1 to 25 motor turns before the completely open position may be set.
21 30	Setting automatic closing time The timer starts from the gate open state and continues for the set time. Once the set time is reached, the gate closes automatically. The timer count restarts if a photocell is triggered. IMPORTANT: persistent activation of the opening command prevents automatic reclosure; the automatic reclosure time count is resumed when the opening command is released.
00-90	Pause time settable from 00 to 90 s.
92-99	Pause time settable from 2 to 9 min.
22 00	Enabling of management for opening with automatic reclosure exclusion If enabled, the exclusion of automatic reclosure only applies for the command selected via the parameter. For example: if you set 220 i, automatic reclosure is excluded following an AP command, but it is activated following a PP or PED command. NB: a command activates a manoeuvre in the open-stop-close or close-stop-open sequence.
00	Disabled.
0 1	An AP (opening) command activates the opening manoeuvre. With the gate fully open, automatic reclosure is excluded. An AP (open) or CH (close) command activates the closure manoeuvre.
02	A PP (step mode) command activates the opening manoeuvre. With the gate fully open, automatic reclosure is excluded. Another PP (step mode) command activates the closure manoeuvre.
03	A PED (partial opening) command activates the partial opening manoeuvre. Automatic reclosure is excluded. Another PED (partial opening) command activates the closure manoeuvre.
23 10	Regulating the automatic closing time after opening pedestrian gate The timer starts from the moment the gate is fully open; The timer count restarts if a photocell is triggered.
00-90	pause time settable from 00 to 90 s.
92-99	pause time settable from 2 to 9 min.
25 03	Adjusting opening delay (alignment) of MOTOR 2 During opening, MOTOR 2 starts with an adjustable delay after MOTOR 1.
00- 10	From 0 to 10 s.
26 05	Adjusting closing delay (alignment) of MOTOR 1 During closing, MOTOR 1 starts with an adjustable delay after MOTOR 2.
00-30	From 0 to 30 s.
27 03	Setting reverse time after activation of sensing edge or obstacle detection (crush prevention) This sets the reverse manoeuvre time after activation of the sensing edge or the obstacle detection system.
00-60	From 0 to 60 s.
28 00	Select type of electric lock
00	Normally UNPOWERED electric lock (powered only for 3 s when opening starts). N.B.: The electric lock is enabled by parameter 29.
0 1	"ventouse" type electric block (normally powered when the gate is completely closed). Not powered when gate is moving.
02	"ventouse" type electric block (normally powered when the gate is completely opened or completely closed). Not powered when gate is moving.
10- 12	Electric lock of normally NOT powered type, with adjustable timing 10=0.5 seconds; 11=1 second; 12=1.5 seconds.
29 00	Enable electric lock
00	Disabled.
0 1	Enabled. When LEAF 1 approaches the gate closed stop, the controller delivers supplementary power to MOTOR 1 to latch the electric lock.
02	Enabled. When LEAF 1 approaches the gate closed stop, the controller delivers maximum power to MOTOR 1 to latch the electric lock. The obstacle detection system is disabled.

30 07	Setting MOTOR 1 torque Increasing or decreasing the value of the parameter increases or decreases motor torque and, as a result, adjusts obstacle detection sensitivity. Use values below 03 SOLO ONLY for particularly lightweight installations not exposed to severe weather conditions (strong winds or very cold temperatures). In installations with gate leaves of different lengths, they torque value may be set separately, setting a value for parameter 33 between 01 and 09.
31 07	Setting MOTOR 2 torque Increasing or decreasing the value of the parameter increases or decreases motor torque and, as a result, adjusts obstacle detection sensitivity. Use values below 03 SOLO ONLY for particularly lightweight installations not exposed to severe weather conditions (strong winds or very cold temperatures). In installations with gate leaves of different lengths, they torque value may be set separately, setting a value for parameter 33 between 01 and 09.
01-09	01= -35%; 02= -25%; 03= -16%; 04= -8% (reduced motor torque = increased sensitivity). 05= 0%. 06= +8%; 07= +16%; 08= +25%; 09= +35% (increased motor torque = reduced sensitivity).
32 15	Setting obstacle impact force sensitivity MOTOR 1 If the reaction time to obstacle impact force is too long, reduce the value of the parameter. If the impact force exerted on obstacles is too high, reduce the value of parameter 30. N.B.: repeat the acquisition procedure after any change made to this parameter.
33 15	Setting obstacle impact force sensitivity MOTOR 2 If the reaction time to obstacle impact force is too long, reduce the value of the parameter. If the impact force exerted on obstacles is too high, reduce the value of parameter 30 (or 33, if enabled: 33 different from 10). N.B.: repeat the acquisition procedure after any change made to this parameter.
01-10	Low motor torque: 01 = minimum obstacle impact force ... 10 = maximum obstacle impact force N.B.: only use these settings if the medium motor torque values are not suitable for the installation.
11-16	Medium motor torque. Recommended setting for adjusting force settings correctly. 11 = minimum obstacle impact force ... 16 = maximum obstacle impact force.
17	Motor torque at 70% of the maximum value, intervention time 1 s. The use of the sensing edge is mandatory.
18	Motor torque at 80% of the maximum value, intervention time 2 s. The use of the sensing edge is mandatory.
19	Motor torque at 100%, intervention time 2 s. The use of the sensing edge is mandatory.
20	Motor torque at 100%, intervention time 3 s. The use of the sensing edge is mandatory.
34 08	Setting start acceleration MOTOR 1 during opening
35 08	Setting start acceleration MOTOR 2 during opening
01-10	01 = the gate accelerates rapidly at start of manoeuvre ... 10 = the gate accelerates slowly and progressively at start of manoeuvre.
36 08	Setting start acceleration MOTOR 1 during closing
37 08	Setting start acceleration MOTOR 2 during closing
01-10	01 = the gate accelerates rapidly at start of manoeuvre ... 10 = the gate accelerates slowly and progressively at start of manoeuvre.
38 00	Enable electric lock release reverse impulse
00	Disabled.
01	Enabled. The controller applies a brief closing force (max. 4 s) to release the electric lock.
40 07	MOTOR 1 opening speed setting (%)
41 07	MOTOR 2 opening speed setting (%)
01-10	01 = minimum speed ... 10 = maximum speed. NOTE: the speed depends on the model of gear motor in use
42 07	MOTOR 1 closing speed setting (%)
43 07	MOTOR 2 closing speed setting (%)
01-10	01 = minimum speed ... 10 = maximum speed. NOTE: the speed depends on the model of gear motor in use

4405	MOTOR 1 end of manoeuvre constant approach speed setting Once deceleration is complete, the gate continues moving at a constant speed until it encounters the mechanical stop (or the limit switch, if installed). The space is regulated by the parameters from Y0 and Y2.
4505	MOTOR 2 end of manoeuvre constant approach speed setting Once deceleration is complete, the gate continues moving at a constant speed until it encounters the mechanical stop (or the limit switch, if installed). The space is regulated by the parameters from Y1 and Y3.
01-10	01=minimum speed ... 10=maximum speed NOTE: The minimum and maximum approach speeds vary according to the gear motor installed. The settings are divided in constant size steps. The maximum setting for the approach speed is equivalent to 75% of the maximum speed selectable using par. 40...43
4901	Setting number of automatic closure attempts after activation of sensing edge or obstacle detection (crush protection)
00	No automatic closure attempts.
01-03	From 1 to 3 automatic closure attempts. We recommend setting a value equal to or lower than the value set for parameter R2. Automatic closure is only performed if the gate is completely open.
5000	Setting photocell mode during gate opening (FT1)
00	DISABLED. Photocell is not active or not installed.
01	STOP. The gate stops and remains stationary until the next command is received.
02	IMMEDIATE REVERSE. The gate reverses immediately if the photocell is activated during gate opening.
03	TEMPORARY STOP. The gate stops as long as the photocell is obstructed. The gate resumed opening when the photocell is cleared.
04	DELAYED REVERSE. The gate stops if the photocell is obstructed. The gate closes when the photocell is cleared.
5102	Setting photocell mode during gate closing (FT1)
00	DISABLED. Photocell is not active or not installed.
01	STOP. The gate stops and remains stationary until the next command is received.
02	IMMEDIATE REVERSE. The gate reverses immediately if the photocell is activated during gate opening.
03	TEMPORARY STOP. The gate stops as long as the photocell is obstructed. The gate resumed opening when the photocell is cleared.
04	DELAYED REVERSE. The gate stops if the photocell is obstructed. The gate closes when the photocell is cleared.
5201	Photocell (FT1) mode with gate closed N.B.: this parameter is not visible if R0 02 or R0 03 or R0 04 is set.
00	If the photocell is obstructed, the gate cannot open.
01	The gate opens when an open command is received, even if the photocell is obstructed.
02	The photocell sends the gate open command when obstructed.
5300	Setting photocell mode during gate opening (FT2)
00	DISABLED. Photocell is not active or not installed.
01	STOP. The gate stops and remains stationary until the next command is received.
02	IMMEDIATE REVERSE. The gate reverses immediately if the photocell is activated during gate opening.
03	TEMPORARY STOP. The gate stops as long as the photocell is obstructed. The gate resumed opening when the photocell is cleared.
04	DELAYED REVERSE. The gate stops if the photocell is obstructed. The gate closes when the photocell is cleared.
5400	Setting photocell mode during gate closing (FT2)
00	DISABLED. Photocell is not active or not installed.
01	STOP. The gate stops and remains stationary until the next command is received.
02	IMMEDIATE REVERSE. The gate reverses immediately if the photocell is activated during gate opening.
03	TEMPORARY STOP. The gate stops as long as the photocell is obstructed. The gate resumed opening when the photocell is cleared.
04	DELAYED REVERSE. The gate stops if the photocell is obstructed. The gate closes when the photocell is cleared.

55 01	Photocell (FT2) mode with gate closed N.B.: this parameter is not visible if AB 02 or AB 03 or AB 04 is set.		
00	If the photocell is obstructed, the gate cannot open.		
01	The gate opens when an open command is received, even if the photocell is obstructed.		
02	The photocell sends the gate open command when obstructed.		
56 00	Enable close command 6 s after activation of photocell (FT1-FT2) This parameter is not visible if AB 03 or AB 04 is set. NOTE: in the case of photocells being blanked during opening, the 6 secs. count starts when the wings are completely open.		
00	Disabled.		
01	Enabled. When the photocell gate FT1 is crossed, a close command is sent 6 seconds later.		
02	Enabled. When the photocell gate FT2 is crossed, a close command is sent 6 seconds later.		
57 00	Selecting contact type (NC or 8.2 kOhm) on inputs FT1/FT2/ST In conformity with the safety regulations EN12453-EN12445, devices using an 8.2 kOhm contact instead of an NC contact may be connected to inputs FT1/FT2/ST . The controller unit must therefore be configured accordingly.		
	FT1	FT2	ST
00	The controller is configured for NC contacts by default.		
01	8k2	N.C.	N.C.
02	N.C.	8k2	N.C.
03	8k2	8k2	N.C.
10	N.C.	N.C.	8k2
11	8k2	N.C.	8k2
12	N.C.	8k2	8k2
13	8k2	8k2	8k2
58 00	Selecting the type of photocell test on input FT1 This parameter is visible if AB 02 or AB 04 is set. If the photocell test is enabled, the control unit will check the photocells connected to input FT1 are working properly. The test lasts max. 3 s OFF / 3 s ON.		
59 00	Selecting the type of photocell test on input FT2 This parameter is visible if AB 02 or AB 04 is set. If the photocell test is enabled, the control unit will check the photocells connected to input FT2 are working properly. The test lasts max. 3 s OFF / 3 s ON.		
00	Photocell test disabled.		
01	Photocell test enabled on opening ONLY.		
02	Photocell test enabled on closure ONLY.		
03	Photocell test enabled on both opening and closure.		
60 00	Enable MOTOR 1 limit switch NOTE: this parameter is displayed only if MOTOR 1 is fitted with internal limit switches.		
61 00	Enable MOTOR 2 limit switch NOTE: this parameter is displayed only if MOTOR 2 is fitted with internal limit switches.		
00	Limit switches disabled.		
01	Opening limit switch only.		
02	Closing limit switch only.		
03	Both limit switches.		
63 00	Enable MOTOR 1 braking NOTE: this parameter is displayed only if required by the MOTOR 1 type (REVERSIBLE or HIGH-SPEED).		
64 00	Enable MOTOR 2 braking NOTE: this parameter is displayed only if required by the MOTOR 2 type (REVERSIBLE or HIGH-SPEED).		
00	Electrical braking when motor stopped disabled.		
01	Electrical braking enabled.		
65 05	Setting MOTOR 1 stop distance		
66 05	Setting MOTOR 2 stop distance		
0 1-05	0 1= faster deceleration/shorter stop distance ... 05= slower deceleration/longer stop distance.		

67 00	Enable MOTOR 1 internal electric lock NOTE: this parameter is displayed only if required by the MOTOR 1 type (REVERSIBLE or HIGH-SPEED).
68 00	Enable MOTOR 2 internal electric lock NOTE: this parameter is displayed only if required by the MOTOR 2 type (REVERSIBLE or HIGH-SPEED).
00	Electric lock disabled.
01	Electric lock enabled, closed position sensor only.
02	Electric lock enabled, open position sensor only.
03	Electric lock enabled, both sensors present.
70 02	Select number of motors installed
01	1 motor.
02	2 motors.
71 01	Selecting installation position of motor relative to gate MOTOR 1 (seen from interior side) N.B.: in the event of a reset to restore the default parameters, this parameter must be set again manually.
72 00	Selecting installation position of motor relative to gate MOTOR 2 (seen from interior side) N.B.: in the event of a reset to restore the default parameters, this parameter must be set again manually.
00	Motor installed on left.
01	Motor installed on right.
73 03	Configuring sensing edge COS1
00	Sensing edge NOT INSTALLED.
01	NC contact (normally closed). The gate reverses only when opening.
02	Contact with 8k2 resistor. The gate reverses only when opening.
03	NC contact (normally closed). The gate always reverses.
04	Contact with 8k2 resistor. The gate always reverses.
12	Management of two 8k2 sensitive edges connected in parallel (total resistance 4k1). The gate reverses only when opening.
14	Management of two 8k2 sensitive edges connected in parallel (total resistance 4k1). The gate always reverses.
74 00	Configuring sensing edge COS2
00	Sensing edge NOT INSTALLED.
01	NC contact (normally closed). The gate reverses only when opening.
02	Contact with 8k2 resistor. The gate reverses only when opening.
03	NC contact (normally closed). The gate always reverses.
04	Contact with 8k2 resistor. The gate always reverses.
12	Management of two 8k2 sensitive edges connected in parallel (total resistance 4k1). The gate reverses only when opening.
14	Management of two 8k2 sensitive edges connected in parallel (total resistance 4k1). The gate always reverses.
76 00	Configuring radio channel 1 (PR1)
77 01	Configuring radio channel 2 (PR2)
00	STEP MODE
01	PARTIAL OPENING
02	OPENING
03	CLOSING
04	STOP
05	Courtesy light. The output COR is managed from the remote control. The light remains lit as long as the remote control is active. The parameter 79 is ignored.
06	Courtesy light ON-OFF (PP). The output COR is managed from the remote control. The remote control turns the courtesy light on and off. The parameter 79 is ignored.
07	STEP MODE with confirmation for safety ⁽¹⁾ .
08	PARTIAL OPENING with confirmation for safety ⁽¹⁾ .
09	OPENING with confirmation for safety ⁽¹⁾ .
10	CLOSURE with confirmation for safety ⁽¹⁾ .

⁽¹⁾ To prevent gate maneuver caused by accidentally pressing a remote control button, confirmation is required to enable the command.

• Example: parameters 76 07 and 77 01 set:

• Pressing the CHA button on the remote control selects the step mode function, which must be confirmed within 2 seconds by pressing CHB on the remote control. Press CHB to activate partial opening.

78 00	Configuring flashing light frequency
00	The frequency is set electronically from the flashing light unit.
01	Slow flash.
02	Light flashes slowly when gate opens, rapidly when gate closes.



79 60	Selecting courtesy light mode NOTE: the parameter is not visible if par. 1B other than 00.
00	Disabled.
01	PULSE. The courtesy light illuminates briefly at the start of each manoeuvre.
02	ACTIVE. The light remains lit for the entire duration of the manoeuvre.
03-90	From 3 to 90 s. The light remains lit for the time period set after the manoeuvre is completed.
92-99	From 2 to 9 minutes. The light remains lit for the time period set after the manoeuvre is completed.

80 00	Clock contact configuration (ORO) When the clock function is active, the gate opens and remains open. At the end of the programmed time set with the external device (clock), the gate closes.
00	When the clock function is active, the gate opens and remains open. Any command signal received is ignored.
01	When the clock function is active, the gate opens and remains open. Any command signal received is accepted. When the gate returns to the completely open position, the clock function is reactivated.

81 00	Enable safeguarded gate closure/opening Enabling this parameter ensures that the gate is not left open due to an incorrect and/or accidental command. This function is NOT enabled if: <ul style="list-style-type: none"> • the gate receives a STOP command; • the sensitive edge intervenes, detecting an obstacle in the same direction in which the function is enabled. If instead the sensitive edge detects an obstacle during the movement opposite to the one guaranteed, the function remains active. • the number of closure attempts set by parameter 82 has been reached; • the acquired position is lost (perform position recovery, see chapter 16).
00	Disabled. The parameter 82 is not displayed.
01	Safeguarded closure enabled. After a period of time set with parameter 82, the control unit signals a 5 second warning with the flashing light, regardless of the parameter 85, and then closes the gate.
02	Safeguarded closure / opening enabled. If the gate is closed as a result of a step mode command, after a period of time set with parameter 82, the control unit signals a 5 second warning with the flashing light (regardless of the parameter 85), and then the gate closes. If the gate is stopped by the obstacle detection system during a closure manoeuvre, the gate closes after a period of time set with parameter 82. If the gate is stopped by the obstacle detection system during an opening manoeuvre, the gate closes after a period of time set with parameter 82.

82 03	Setting safeguarded closure/opening activation time N.B.: this parameter is not visible if the value of parameter 81 = 00.
02-90	Wait time settable from 2 to 90 s.
92-99	Wait time settable from 2 to 9 min.



83 00	Selecting limitations in battery operation N.B.: the parameter is visible only if par. 85 is different than 00
00	There is no limitation for the commands when the battery voltage drops under the selected threshold. An error alert may be activated via the COR output (if parameters 85 and 1B are adequately set).
01	When the battery voltage drops under the threshold selected with par. 85, the control unit accepts only opening commands and does not perform closing.
02	When the battery voltage drops under the threshold selected with par. 85, after a 5 s pre-flashing, the control unit automatically opens the barrier's boom and accepts only a closing command.
03	It accepts only closing commands even if the ORO input is active and if the parameter is 80 01.
04	When the battery voltage drops to the threshold selected with par. 85 the control unit, after a prelamp of 5s, automatically closes the gate and accepts only one opening command.

84 00	Battery type selection and consumption reduction
00	36V $\overline{\text{---}}$ (3x12 V $\overline{\text{---}}$) battery with B71/BCIPU coupling battery charger. Acceleration/deceleration/speed reduction enabled, to increase the battery life, flashing frequency reduced.
01	36V $\overline{\text{---}}$ (3x12 V $\overline{\text{---}}$) battery with B71/BCIPU coupling battery charger. No performance reduction, maximum battery consumption.
02	36V $\overline{\text{---}}$ (3x12V $\overline{\text{---}}$) battery with external charger B71/PBX. Acceleration/deceleration/speed reduction enabled, to increase the battery life.
03	36V $\overline{\text{---}}$ (3x12V $\overline{\text{---}}$) battery with external charger B71/PBX. No performance reduction, maximum battery consumption.
85 00	Selection of the battery operation management
	Setting a value different than 00 a battery voltage level check is activated. The desired operation type can be selected via parameter B3 and an error alert can be activated through the COR output via parameter 18.
00	The control unit always accepts commands until the battery is completely exhausted (35.4V $\overline{\text{---}}$, lighting of icon  below the battery icon: controls disabled).
01	The command becomes active when the battery voltage drops to the minimum threshold (36.4V $\overline{\text{---}}$ for battery 3x12V $\overline{\text{---}}$).
02	The command becomes active when the battery voltage drops to the medium threshold (36.8V $\overline{\text{---}}$ for battery 3x12V $\overline{\text{---}}$).
03	The command becomes active when the battery voltage drops to the maximum threshold (37.2V $\overline{\text{---}}$ for battery 3x12V $\overline{\text{---}}$).
86 00	Enabling of regular maintenance activation
	N.B.: Parameter visible if any password other than the default password is set (00000000). N.B.: in the event of a reset to restore the default parameters, this parameter must be set again manually. When the manoeuvre hour limit (set by B5 and B7) is exceeded, the visual maintenance signal is activated (e.g. every 1500 manoeuvre hours). ATTENTION: a manoeuvre is any activation of the automation system while being open. On the display below the parameter box the symbol  is shown, followed by the number of hours since the last maintenance; with the motors stopped, the flashing light unit will activate at regular intervals (1 s on / 4 s off) until the system maintenance is performed and the alarm is reset. To reset the alarm, unlock the protection by entering the password and press the "+" and "-" keys for 5 s. The symbol  disappears from the display, the number of operating hours is stored in the memory and the count starts again. N.B.: When 9990 hours of operation are exceeded, the maintenance alarm is disabled entirely.
00	Disabled.
01	Maintenance enabled for a period = parameter value B7 x10 hours.
02	Maintenance enabled for a period = parameter value B7 x100 hours.
87 00	Adjustment of regular maintenance activation hour counter
	N.B.: Parameter visible with parameter B6 01 or B6 02. N.B.: in the event of a reset to restore the default parameters, this parameter must be set again manually.
00	Disabled.
01-99	from 10 to 990 hours with parameter B6 01. from 100 to 9990 hours with parameter B6 02. Maximum limit: 9990 hours (beyond this value the maintenance alarm is disabled entirely).
88 00	Cyclical activation (test mode)
	The automation system is activated in opening mode at intervals defined by the parameter; automatic closing must be selected (par.B2 and par.c1).
00	Disabled.
15-90	Opening command activated every 15"...90".
91-99	Opening command activated every 1"...9".
89 00	Activating firmware update mode for the inverters (on board the motor)
	NOTE: set 01 or 02 to modify the displayed menu, switching to the updated version; to perform the update, it is necessary to use B74/BCONNECT and the corresponding WEB application
00	Setting the value 00 forces the F70/IPU36 to reset
01	Preparations for updating the inverter firmware on MOTOR 1.
02	Preparations for updating the inverter firmware on MOTOR 2.
03	Provision for firmware upgrade of B73/KEYS on EXP1 connector.
04	Provision for firmware upgrade of B73/KEYS on EXP2 connector.
90 00	Restoring factory default values
	NOTE This procedure is only possible if NO data protection password is set. Pressing and holding the "+" and "-" keys for 4 seconds resets the standard parameters (see the description at par. 10.2)

X0 00	Enable B73/RGB connected to MOTOR 1
X1 00	Enable B73/RGB connected to MOTOR 2
00	Disabled.
01	Enabled with traffic light function RG (RED - GREEN).
02	Enabled with signalling function RGB (RED - GREEN - BLUE).
X2 00	Select RG beacon operating mode (see type descriptions, figure 8)
00	Disabled.
01-06	"Type A"..."type F" mode.
X3 00	Select RGB signalling operating mode (see type descriptions, figure 8)
00	Disabled
01-08	"Type A"..."type H" mode.
X4 00	Enabling incoming colour transition at full aperture NOTE: By setting a value other than 00, only for modes type 'A', 'B', 'F', 'G' of RGB lights, when the indicated aperture percentage is reached, the colour transitions to the selected colour.
00	Disabled, the colour remains as per par. X2/X3.
01-05	Transition to orange colour when MOTOR 1 reaches 70-75-80-85-90% of its travel.
06-10	Transition to green colour when MOTOR 1 reaches 70-75-80-85-90% of its travel.
X5 00	Select RGB colour in stand-by Once the automation system is fully closed, the colour assumes the selected value after the time interval defined in par. X6 has elapsed.
00	Sequence of the various colours, with dimmed brightness.
01-09	1: blue, 2: yellow, 3: pink, 4: light blue, 5: fuchsia, 6: white, 7: orange, 8: violet, 9: red.
X6 00	Select the RGB lights stand-by time (when fully closed)
00	Stand-by disabled, the colour remains as selected in par. X2 (or X3).
01-20	Stand-by time 30", 60", 90", 2 minutes, 10 minutes.
X7 00	B73/KEYS keyboard enabling NOTE: operation on EXP2 connector is only possible if the automation also uses motor 2
00	Disabled
01	Enabled on EXP1 connector
02	Enabled on EXP2 connector
03	Enabled on two keyboards, one on EXP1 and one on EXP2
Y0 10	Setting the approach space of MOTOR 1 in OPENING
Y1 10	Setting the approach space of MOTOR 2 in OPENING
00-80	from min. 0 to max. 80 revolutions which the motor makes at the minimum speed set according to par. 44 or 45.
Y2 10	Setting the approach space of MOTOR 1 in CLOSING
Y3 10	Setting the approach space of MOTOR 2 in CLOSING
00-80	from min. 0 to max. 80 revolutions which the motor makes at the minimum speed set according to par. 44 or 45.

Y4 00	Enable maximum torque boost when starting MOTOR 1 If this parameter is enabled, each time the motor starts a manoeuvre, maximum torque is produced for a maximum of 5 seconds, or for the time necessary for the gate to open by approximately 65 cm. NOTE: in the case of HIGH SPEED and REVERSIBLE motors a boost period of 2 s is enabled at each start-up, irrespective of the parameter Y4 setting.
Y5 00	Enable maximum torque boost when starting MOTOR 2 If this parameter is enabled, each time the motor starts a manoeuvre, maximum torque is produced for a maximum of 5 seconds, or for the time necessary for the gate to open by approximately 65 cm. NOTE: in the case of HIGH SPEED and REVERSIBLE motors a boost period of 2 s is enabled at each start-up, irrespective of the parameter Y5 setting.
00	Disabled.
01	Enabled at start of opening manoeuvre only (including position recovery). The motor starting current function is only enabled for closing maneuver if the gate position is known and the gate is over to 2 metres from the completely closed position.
02	Enabled for all starts (including position recovery).
Y6 00	Setting motor torque during position recovery MOTOR 1 Allows the motor torque to be adjusted if during position recovery the values set at parameters 30 and 32 are inadequate to ensure the gate completes the manoeuvre. If position recovery is not completed, normal gate operation will not be resumed.
Y7 00	Setting motor torque during position recovery MOTOR 2 Allows the motor torque to be adjusted if during position recovery the values set at parameters 31 and 33 are inadequate to ensure the gate completes the manoeuvre. If position recovery is not completed, normal gate operation will not be resumed.
00	The response of the obstacle detection system depends solely on the values set for parameters 30 and 32 (MOTOR 1) and 31 and 33 (MOTOR 2).
01	The response of the obstacle detection system depends on the values set for parameter 30 and 32 (MOTOR 1) and 31 and 33 (MOTOR 2) and on the maximum current value stored during travel acquisition.
02	The response of the obstacle detection system is a 70% reduction in maximum torque for a period of 1 s.
03	The response of the obstacle detection system is a 80% reduction in maximum torque for a period of 2 s.
04	The response of the obstacle detection system is a 100% reduction in maximum torque for a period of 2 s.
05	The response of the obstacle detection system is a 100% reduction in maximum torque for a period of 3 s.

13 Alarms and faults

PROBLEM	ALARM	POSSIBLE CAUSE	ACTION
The gate does not open or close.	the safety devices page is displayed without the STOP panel blacked out (i.e. with the STOP contact open)	the ST terminal is not connected to the STOP button (N.C.) or is not bridged with COM or F70/IPU36 has detected an alarm that must prevent movement and forces a STOP	install button or connect jumper. Check the alarm reporting.
	the error alert SEL.MOT. is displayed	the parameter <i>RD</i> or <i>RI</i> on F70/IPU36 does not correspond to the value saved in the EEPROM of inverter 1 or 2	save the correct value for the motor in use
	the icon is displayed 	the inverter was not initialised when calibration the motor	execute the motor calibration procedure
	the icon is displayed 	the motor phases are not connected to the respective terminal block on the inverter	check the motor phases are connected to the inverter correctly, or if there are any interruptions in the internal connections
	the icon is displayed 	if the error alert appears on its own: possible data storage phase in inverter EEPROM, communications suspended temporarily	if this error alert appears on its own, but no data storage operations are currently in active, reroute the cables to avoid the risk interference; check the length and cross section of the connecting cables
		if the error alert remains stable: connection error between F70/IPU36 and inverter or damaged inverter (or communication section with inverter damaged on board F70/IPU36)	if the error alert remains stable: check that the connection is correct; try switching the F70/IPU36 off, and then on again
The photocells/peripheral devices supplied via the 24 V output switch off for a few seconds, and then switch on again.	if the VL indicator (voltage supplied to 24 V output) on the control menu page displays a value of approximately 20 V	it means there are too many photocells/peripheral devices connected (overload); a short circuit has been detected on the 24 V output (the electronic protection device has tripped)	reduce the load on the 24 V output, in accordance with the indications set out in the technical specifications table; check for any incorrect connections or faulty devices that might overload the output

14 Inverter module

The inverter module in the motor receives serial commands via RS485 from the control unit and controls the motor by performing the required manoeuvre. In the event an obstacle is encountered, the manoeuvre is reversed automatically and the alarm condition is transmitted to the control unit, which executes the same manoeuvre using the second motor, if present, maintaining synchronisation of the automation system.

Communication between the inverter module and control unit is continuous, as indicated by the regular flashing of the red LED L1 (fig. 8).

VISUAL INDICATIONS

RED LED (L1M)

- flashing rapidly at regular intervals: data communication with control unit in progress, correct operation
- 4 rapid flashes followed by a pause, sequence repeated: inverter in alarm state (consult diagnostic icon on control unit display), see paragraph 10.5)
- 1 short flash at long intervals: loss of communication with control unit (control unit locked, cable not connected correctly or RS485 drivers damaged)
- off: motor calibration in progress (communication with control unit interrupted)

GREEN LED (L2M)

- Normally off
- 1 slow flash open command received
- 2 slow flashes: close command received
- 1 very slow flash: stop command received
- on in steady state: motor calibration in progress

- 4 rapid flashes: motor calibration/travel acquisition completed successfully
- 8 rapid flashes: error during motor calibration/travel acquisition: operation not completed
- repetitive rapid flashes: travel acquisition in progress

Other signals:

GREEN AND RED LED

- on for 1 second: when the inverter module is switched on
- 4 slow, alternating flashes RED-GREEN-RED-GREEN: possible FW update command reception phase (bootloader active)
- repetitive, rapid alternating flashes: FW update in progress
- repetitive, slow alternating flashes: FW update failed, repeat the procedure (motor functions no longer available, motor disabled until new update)

15 Mechanical release

In the event of a power failure, it is possible to unlock the gate, as indicated in the automation use and maintenance manual.

When the voltage is restored and the first command is received, the control unit initiates an opening manoeuvre in position recovery mode, unless the electric position limit switches have been installed and the gate is already in a position where it activates one of them.

In the case of automation systems that also manage a release contact, activating the release automatically causes the position of the gate to be lost, as the STOP command that inhibits any activation. The next time the lock is reset, the control unit starts the position recovery manoeuvre once it receives the first command.

16 Position recovery procedure in the ABSENCE of limit switches

On receiving the first command signal after a power failure or after detecting an obstacle in the same position three consecutive times, the control unit starts a manoeuvre in position recovery mode.

Therefore, the automation system initiates a low speed manoeuvre. The flashing light flashes with a different duty cycle than normal (3 s on, 1.5 s off).

The control unit recovers the installation data during this procedure. **Warning:** Do not give any commands at this stage until the automation system has performed a complete manoeuvre.

If the gate is released in the completely open or completely closed position with the control unit powered, always return the gate leaves into their original positions before locking the gate release again. The gate will resume normal operation on receipt of the first control command.

WARNING: Releasing the gate in an intermediate position is not recommended, at it may cause the leaf position parameters to be lost (see parameters CNT1 / CNT2 in INFO mode, par 10.4). In this case, a position recovery procedure is necessary.

Should the wings not be returned to the same position in which they were before the manual handling, the data relative to their position will be lost, therefore:

- The wings movement gets inverted on the mechanical strike plates (obstacle detection).
- Activation of a PP command (step mode) activates the opposite manoeuvre (example: if the gate was closing, it opens).
- The control unit detects an anomaly in the motor revs count and automatically:
 1. activates the position recovery mode;
 2. stops the motors for 0.4 s;
 3. the wings resume the manoeuvre at low speed through to the striker plate;
 4. on the subsequent Step by Step command (PP), the wings carry out the manoeuvre at low speed again.
- Leave the wings to carry out a complete manoeuvre to restore normal operation mode.

POSITION RECOVERY PROCEDURE IN THE PRESENCE OF LIMIT SWITCHES

NOTE: some automation systems may be capable of managing limit switches connected directly to the inverter module inside the system. However, their operation must be managed via the parameters $B0$ and $B1$.

- After an interruption in the electrical power supply, if the gate is not in the fully open or closed position, upon receipt of the first command, the control unit initiates a position recovery manoeuvre.
- When the limit switch is activated, the position of the gate is associated and recovered. in the case of double gates, when both gates have activated a limit switch, the control unit recovers the position and normal operation is restored.

17 Initial testing

The testing must be performed by qualified technical personnel.

The installer is required to measure impact forces and select on the control unit the appropriate speed and torque values to ensure that the motorised door or gate remains within the limits defined by the standards EN 12453 and EN 12445.

Make sure that the provisions in "GENERIC WARNINGS" are observed.

- Turn on the power supply.
- Check that the automation system motors rotate in the correct direction. If the movement of the doors is incorrect, change the value of par. 71 or 72.
- Check that all connected controls are working correctly.
- Check travel and deceleration.
- Check that the safety devices are activated correctly.
- If the photocell test is enabled, check it is working properly by obscuring the photocells and giving a command: the gate leaves must not move.
- If the battery kit is installed, disconnect from mains and check that the batteries are working.
- Disconnect from mains power and disconnect the batteries (if used), then reconnect. Check the correct completion of the position recovery phase when opening and when closing.

18 Declaration of Conformity

The undersigned Dino Florian, legal representative of Roger Technology - Via Botticelli 8, 31021 Mogliano V.to (TV)

DECLARES that the **F70/IPU36** digital control unit is compliant with the provisions established by Community directives:

2014/30/UE

2014/35/UE

2011/65/UE

and that all the standards and/or technical requirements indicated as follows have been applied:

EN 61000-6-3

EN 61000-6-2

EN 60335-1

Last two figures of year in which marking was applied **CE 22**.

Place: Mogliano V.to

Date: 21-02-2022

Signature



